

BONENG



F Parallel Shaft Gearmotor

Modified date 01/2023
Selection Sample C05.0034-EN

Boneng Transmission

www.motiontech.com.au

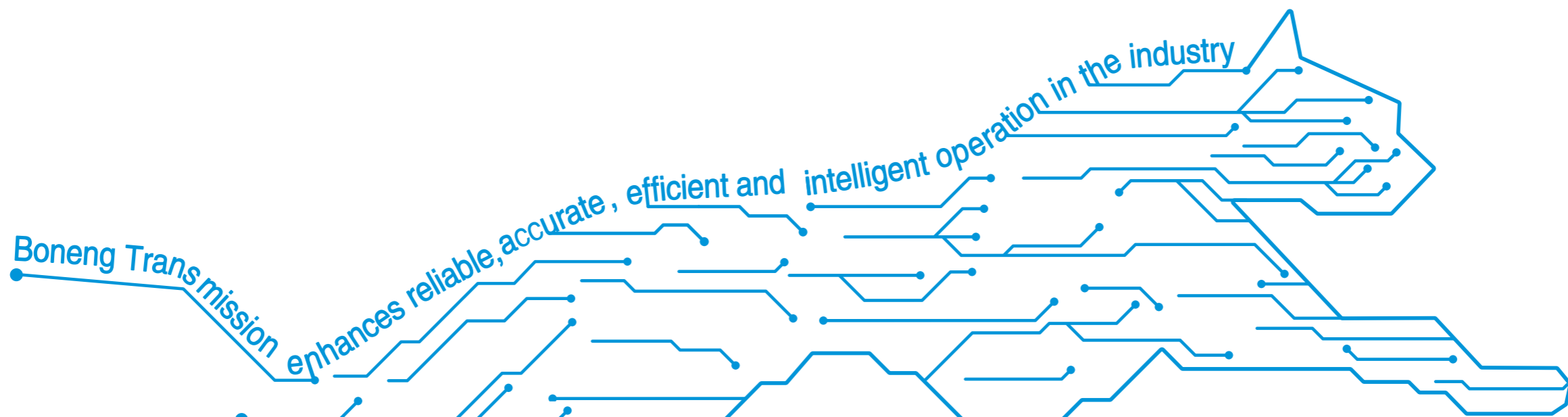

Controller/ Drive/ Motor/ Gearmotor/ Gearbox

Note:

- ◆ The structure scheme, appearance diagram and other attached diagrams in sample are examples, there is no strict proportion requirement. (The unmarked dimension units are mm).
- ◆ The marked weight is average value, it has no constraint force.

You must conform to the following instructions:

- ◆ To prevent accidents, all the rotation parts are added with protective covers according to the safety regulations of the nation and region.
- ◆ Before debugging, you should carefully read instruction book.
- ◆ Gearbox is on running—permission status when delivered, you should add lubrication oil before putting it into running.
- ◆ The marked oil quantity in sample is only reference value, actual oil filling quantity should be the same with the mark on oil immersion lens.
- ◆ Lubrication oil viscosity should be selected according to working situation and application environment temperature of gearmotor.
- ◆ You can only apply lubrication oil of internationally famous brand.

Contents

01.Type Designation	01
02.Mounting Positions	03
03.Type Selection and Example	05
04.Transmission Capacity	07
05.Permissible Radial Force	15
06.Dimensions	17
07.Input Flange and Input shaft	39
08.Combi–type Dimensions	45
09.Motor Rainproof Cover Dimensions	46
10.Recommended Dimensions for Driven Equipment Shaft	47
11.Shaft End Centre Hole	49
12.Dimension of Parallel Key and Keyway	50
13.Oil	51

1 Type Designation

F 3 08 H A - C32 - D1 0 1 -

Series

Stages

2-stage/ 3-stage

Size

Mounting Mode

H=Horizontal foot-mounted
 F=Flange-mounted
 S=Short flange-mounted
 A=Torque arm-mounted
 T=Torque arm-mounted with accessory

Output Mode

A=Unidirectional output shaft
 C=Bidirectional output shaft
 G=Hollow shaft with parallel key
 I=Hollow shaft with shrink disk
 K=Hollow shaft with involute spline

Nominal Ratio Code

Mounting Positions

D1/D2/D3/D4/D5/D6

Accessories and Specific Configuration

0=None

Oil Code

0=Without oil filling(Please select this option when you do not need lubricating oil);
 1=With mineral oil VG220(Please select this option when the ambient temperature is $-20^{\circ}\text{C}\sim+40^{\circ}\text{C}$, and you need lubricating oil);
 5=With synthetic lubricating oil VG220(It is recommended to select this option when you need lubricating oil and the ambient temperature is below 0°C);

Note ¹⁾ Motor Type/Frame Size/Poles/Power Code

Power kW	4-pole Type	Power kW	4-pole Type	Power kW	4-pole Type	Power kW	4-pole Type
0.12	MA063M4A12	1.1	MA090M4B11	11	MA160M4C11	55	MA250M4C55
0.18	MA063M4A18	1.5	MA090M4B15	15	MA160L4C15	75	MA280S4C75
0.25	MA071M4A25	2.2	MA100M4B22	18.5	MA180M4C18	90	MA280M4C90
0.37	MA071M4A37	3	MA100M4B30	22	MA180L4C22		
0.55	MA080M4A55	4	MA112L4B40	30	MA200M4C30		
0.75	MA080M4A75	5.5	MA132L4B55	37	MA225M4C37		
		7.5	MA132L4B75	45	MA225M4C45		

MA 132M 4 B55 A C 6 - A 0 N 0 0 - 0 1 1

Cable Entry Position

1 / 2 / 3 / 4

Terminal Box Position

1 / 2 / 3 / 4

Motor mounting Position 0

Motor protection

0=standard configuration(IP55/F) 1=with rain cover 4=IP65/with metal joint
 5=IP65/with metal joint and rain cover J=with metal joint K=with metal joint and rain cover

Thermal Protection and Heating Protection

0=Without thermal protection and heating Protection 2=Thermal switch 5=Thermistor and heating belt
 1=Thermistor 3= PT100 temperature sensor 6=Thermal switch and heating belt
 4=Heating belt 7= PT100 temperature sensor and heating belt

Brake

N=Without brake
 A=Brake 220–240VAC
 D=Brake with release handle 220–240VAC
 G=Brake with self–lock device 220–240VAC
 K=Brake with micro switch 220–240VAC

Encoder

0=No encoder 1=high–performance HTL encoder(1024P) 2=standard encoder accessories
 3=economic HTL encoder(1024P) 4=high–performance TTL encoder(1024P)

Cooling Method

A=Self–fan cooling
 F=Forced–fan cooling

Frequency/Voltage Code

6=60Hz 460V Δ G=60Hz 230VY J=60Hz 575VY
 8=60Hz 460VY H=60Hz 230V Δ K=60Hz 575V Δ

Note:Alternative code of 3kW and below: 8,G,J;
 Alternative code of 4kW and above: 6,H,K.

Frame Material

L=Die–casting aluminum frame(standard configuration of 100 and below)
 C=Grey cast iron frame(standard configuration of 112 and above)

Mounting Mode A

Power Code¹⁾

Motor Poles¹⁾

4=4–pole

Frame Size¹⁾

Motor Type¹⁾

MA=NEMA efficiency three–phase asynchronous motor

- ◆ **Example of product type with input flange or input shaft:** F308HA–C32–D101–AE300
- ◆ **Example of product type with input flange and motor type:** F308HA–C32–D101–AP132–MA132M4B55FC6–A0N10–011
- ◆ **Combi–type designation:** F308HA/C205–D28–D100–MA080M4A75AL6–A0N00–011

2 Mounting Positions

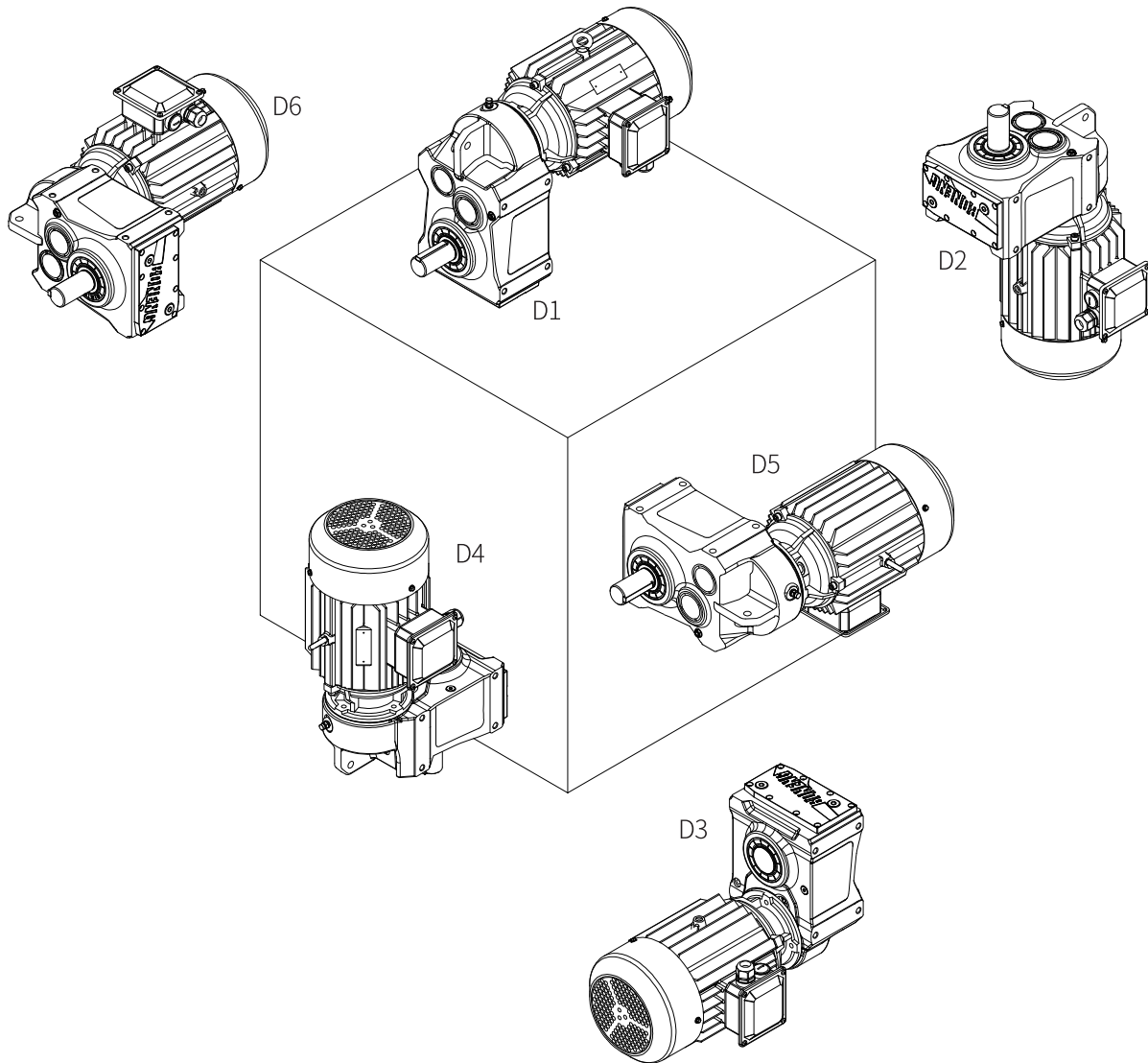

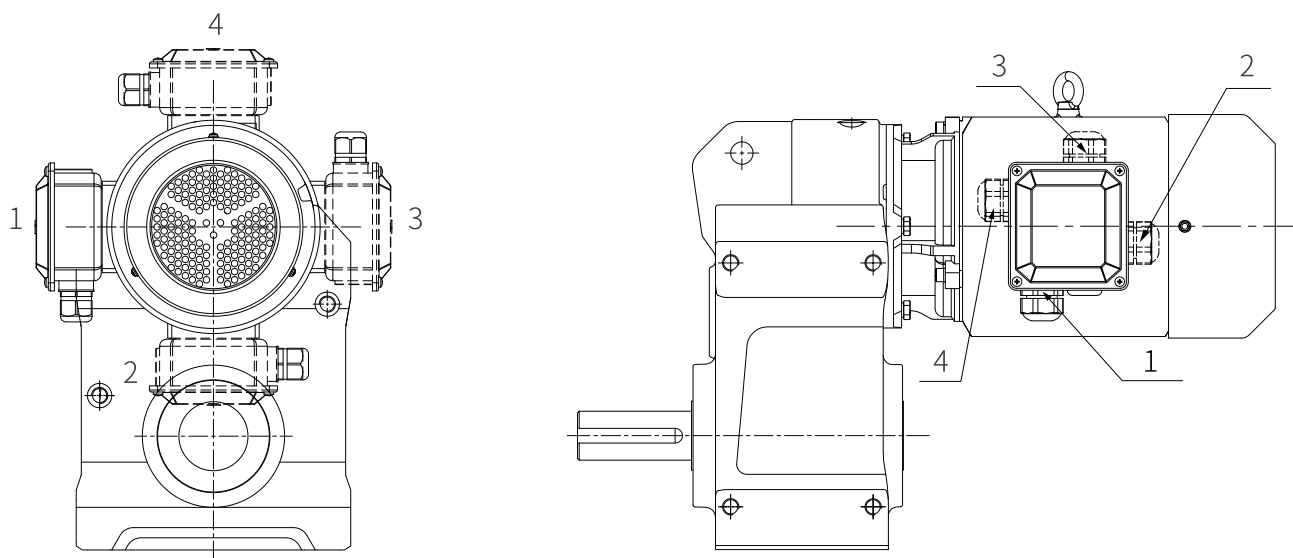
Motor terminal box and cable entry position (View :Motor afterbody)

Assembly colour of gearmotor (RAL5015)

3 Type Selection and Example

Step	Description	Symbol	Parameters Calculation and Guideline			
1	Driven Machine Factor	f_1	Load Characteristic	Operating hours per day (h)		
				≤ 2	2~10	10~24
			Uniform	1.00(1.00)	1.00(1.25)	1.25(1.50)
			Moderate	1.00(1.25)	1.25(1.50)	1.50(1.75)
			Heavy	1.25(1.50)	1.50(1.75)	1.75(2.00)
			Note: Apply values in the brackets when starts per hour are 10 times or more.			
2	Input Speed	n_1	$\leq 1800\text{rpm}$ Consult us if higher speed required.			
3	Calculation of the Ratio	i	$i=n_1/n_2$			
4	Transmission Efficiency	η	F2.. 2-stage: 96% F3.. 3-stage: 94%			
5	Calculation of the input power of the gearunit on basis of the torque and power required by the driven machine.	P_1	$P_1=T_2 \cdot n_1/(9550 \cdot i \cdot \eta)$ or $P_1=P_2/\eta$			
6	Determination of gearunit type referring to the table of transmission capacity after calculation, For directly-connected motor, require to refer to directly-connected motor power table.	T_{2N} 、 P_{1N}	$T_{2N} \geq T_2 \cdot f_1$ or $P_{1N} \geq P_1 \cdot f_1$			
7	Check the radial and axial forces on the shafts.	F_{r1}/F_{r2} F_{a1}/F_{a2}	See the table of Radial Force on Output Shaft (F_{r2}) on P15			
8	Determination of Lubrication system	/	Generally Splash Lubrication			
9	Determination of Cooling System	/	Generally Air Cooling			
10	Determination of every item included in the Type Designation	/	For details about Type Designation, see P01			
11	Normal ambient conditions	/	Ambient temperature -20 to 40°C , ample space, good ventilation, altitude not exceeding 1000m and common plant dust.			
12	Special ambient conditions	/	For higher or lower temperature, dusty sites, chemical reaction (acids, alkaline, etc), or open field (sunlight, ice, rain, etc), please consult us!			

n_2 : The output speed required by the driven machine.
 T_2 : The output torque required by the driven machine.
 P_2 : The output power required by the driven machine.

T_{2N} : The rated output torque of gearmotor.
 P_{1N} : The rated input power of gearmotor.

Example

◆ Known Criteria:

- 1、 Load characteristics by the driven machine:
Heavy, working 16 hours/d and starting 6 times/h;
- 2、 Normal motor: 4-pole 460V 60Hz,
speed $n_1=1740\text{r/min}$;
- 3、 The power required $P_2=2.2\text{KW}$,
speed $n_2=63.3\text{ r/min}$;
- 4、 Mounting mode: flange-mounted,unidirectional output shaft A,
mounting position D1, motor terminal box 1, cable entry position 4.

◆ Selection steps:

- 1、 By referring to the table of Load Characteristic,
we get the driven machine factor $f_1=1.75$;
- 2、 Calculation of the Ratio i_N :
 $i=n_1/n_2=1740/63.3=27.5$, nominal ratio $i_N=28$;
- 3、 Calculation of the input power and determination of the motor power
(transmission efficiency $\eta =94\%$):
 $P_1 \geq P_2 / \eta = 2.2 / 0.94 = 2.3\text{kW}$, so 3kW motor is selected.
Refer to the directly-connected motor power table,
it can be directly-connected;
- 4、 Determination of the nominal power of the geared motor P_{1N} :
 $P_{1N} \geq P_2 \cdot f_1 / \eta = 2.3 \times 1.75 / 0.94 = 4.1\text{kW}$;
- 5、 The type selected: F306FA-C28-D100-MA100M4B30AL8-A0N00-D14

4 Transmission Capacity

4.1 F Transmission capacity

F...(i_N=4-250)

Nominal Input Speed	Nominal Output Speed	Nominal Ratio Code	Nominal Ratio	Rated Output Torque	Exact Ratio	Rated Input Power	Rated Output Torque	Exact Ratio	Rated Input Power
n _{1N} (r/min)	n _{2N} (r/min)	Code	i _N	T _{2N} (N.m)	i _{ex}	P _{1N} (kW)	T _{2N} (N.m)	i _{ex}	P _{1N} (kW)
				F202 F302			F203 F303		
1740	435	B40	4	130	3.95	6.0	160	4.13	7.1
	387	B45	4.5	140	4.46	5.7	170	4.63	6.7
	348	B50	5	140	5.08	5.0	185	5.23	6.4
	311	B56	5.6	150	5.74	4.76	220	5.81	6.9
	276	B63	6.3	150	6.50	4.20	220	6.66	6.0
	245	B71	7.1	150	7.00	3.90	220	7.32	5.5
	218	B80	8	150	7.80	3.50	220	8.25	4.86
	193	B90	9	150	8.79	3.11	220	9.03	4.44
	174	C10	10	150	10.0	2.73	220	10.1	3.95
	155	C11	11.2	150	11.3	2.41	220	11.4	3.50
	139	C13	12.5	150	12.8	2.13	220	12.7	3.15
	124	C14	14	150	13.8	1.98	240	14.6	3.00
	109	C16	16	150	16.0	1.71	240	16.0	2.73
	97	C18	18	150	17.7	1.55	240	18.0	2.42
	87.0	C20	20	150	19.9	1.37	240	19.3	2.27
	77.7	C22	22.4	150	22.7	1.20	240	22.5	1.94
	69.6	C25	25	150	25.7	1.06	240	25.5	1.72
	62.1	C28	28	150	29.1	0.94	240	28.9	1.52
	55.2	C32	31.5	150	31.3	0.87	240	31.1	1.41
	49.0	C36	35.5	150	34.9	0.78	240	34.8	1.26
	43.5	C40	40	150	39.3	0.70	240	38.4	1.14
	38.7	C45	45	150	44.8	0.61	240	43.3	1.01
	34.8	C50	50	150	50.6	0.54	240	49.3	0.89
	31.1	C56	56	150	57.3	0.48	240	55.8	0.78
	27.6	C63	63	150	61.7	0.44	240	63.1	0.69
24.5	C71	71	150	72.3	0.38	240	68.0	0.64	
21.8	C80	80	150	81.9	0.33	240	79.6	0.55	
19.3	C90	90	150	90.3	0.30	240	90.2	0.48	
17.4	D10	100	150	98.7	0.28	240	99.4	0.44	
15.5	D11	112	150	107.9	0.25	240	108.7	0.40	
13.9	D13	125				240	118.8	0.37	
12.4	D14	140							
10.9	D16	160							
9.7	D18	180							
8.70	D20	200							
7.77	D22	224							
6.96	D25	250							

Note:(1) Above the red line are two-stage transmission gearmotor models,model name F2...;

Below the red line are three-stage transmission gearmotor models,model name F3...;

(2) Actual output speed of the gearmotor:Actual input speed (n₁)/Exact ration (i_{ex});

(3) Rated input power corresponding to actual input speed of the gearmotor:P_{1N}=T_{2N}*n₁/ (9550*i_{ex}),the rated output torque T_{2N} in the formula remains unchanged.

Rated Output Torque	Exact Ratio	Rated Input Power	Rated Output Torque	Exact Ratio	Rated Input Power	Rated Output Torque	Exact Ratio	Rated Input Power
T_{2N} (N.m)	i_{ex}	P_{IN} (kW)	T_{2N} (N.m)	i_{ex}	P_{IN} (kW)	T_{2N} (N.m)	i_{ex}	P_{IN} (kW)
F204 F304			F205 F305			F206 F306		
			500	3.81	23.9	560	4.12	24.7
280	4.54	11.2	520	4.37	21.7	580	4.69	22.5
300	5.20	10.5	550	4.96	20.2	600	5.21	21.0
310	5.91	9.6	580	5.55	19.0	600	5.40	20.3
310	6.61	8.5	610	6.18	18.0	660	6.14	19.6
330	7.36	8.2	610	6.79	16.4	660	6.81	17.7
390	8.09	8.8	650	8.00	14.8	700	7.97	16.0
390	9.19	7.7	650	9.10	13.0	700	9.07	14.1
390	9.85	7.2	650	10.2	11.6	700	10.1	12.7
410	11.2	6.7	650	11.3	10.5	750	11.5	11.8
410	12.5	6.0	650	12.5	9.5	830	13.0	11.7
410	13.9	5.4	650	14.1	8.4	850	13.4	11.6
410	15.3	4.88	650	15.5	7.7	900	15.3	10.7
410	17.4	4.29	660	17.6	6.8	900	18.7	8.8
410	19.0	3.93	660	19.8	6.1	900	20.0	8.2
440	21.6	3.70	680	22.2	5.6	900	22.0	7.5
440	24.3	3.30	680	25.1	4.94	900	25.2	6.5
480	27.3	3.20	700	27.8	4.58	900	26.8	6.1
480	30.8	2.84	700	31.9	4.00	900	31.6	5.2
480	34.2	2.55	700	35.0	3.64	900	36.2	4.53
480	39.2	2.23	700	39.3	3.25	900	41.1	3.99
420	43.0	1.78	700	44.4	2.88	900	46.0	3.56
420	48.3	1.58	700	49.2	2.59	900	51.2	3.20
420	54.6	1.40	700	56.4	2.26	900	55.3	2.97
430	60.6	1.29	700	62.0	2.06	900	61.8	2.65
430	69.4	1.13	700	69.9	1.82	900	68.8	2.38
430	76.3	1.03	700	74.7	1.71	900	75.7	2.17
430	86.0	0.91	700	86.8	1.47	900	85.9	1.91
430	91.9	0.85	700	97.7	1.31	900	93.9	1.75
440	106.8	0.75	700	106.7	1.20	900	113.6	1.44
440	120.2	0.67	700	117.0	1.09	900	131.4	1.25
440	144.0	0.56	700	127.1	1.00	900	138.9	1.18
440	156.4	0.51				900	156.2	1.05
						900	166.2	0.99
						900	187.7	0.87

4.1 F Transmission capacity F...(i_N=4-250)

Nominal Input Speed	Nominal Output Speed	Nominal Ratio Code	Nominal Ratio	Rated Output Torque	Exact Ratio	Rated Input Power	Rated Output Torque	Exact Ratio	Rated Input Power
n_{1N} (r/min)	n_{2N} (r/min)	Code	i_N	T_{2N} (N·m)	i_{ex}	P_{1N} (kW)	T_{2N} (N·m)	i_{ex}	P_{1N} (kW)
				F207 F307			F208 F308		
1740	435	B40	4	850	4.01	38.6	2000	3.93	93
	387	B45	4.5	850	4.56	34.0	2200	4.30	93
	348	B50	5	880	4.88	32.9	2400	5.08	86
	311	B56	5.6	880	5.76	27.8	2500	5.70	80
	276	B63	6.3	900	6.48	25.3	2500	6.08	75
	245	B71	7.1	1000	7.10	25.7	2500	6.96	65
	218	B80	8	1000	8.20	22.2	2800	7.74	66
	193	B90	9	1000	8.75	20.8	2800	8.77	58
	174	C10	10	1100	10.4	19.3	3100	9.79	58
	155	C11	11.2	1300	11.3	20.9	3100	11.0	51
	139	C13	12.5	1400	12.7	20.0	3100	11.7	48.2
	124	C14	14	1400	13.9	18.3	3100	13.4	42.1
	109	C16	16	1550	16.1	17.5	3100	14.9	37.9
	97	C18	18	1550	17.2	16.4	3100	16.9	33.4
	87.0	C20	20	1600	19.7	14.8	3100	18.9	29.8
	77.7	C22	22.4	1600	22.6	12.9	3200	21.6	27.0
	69.6	C25	25	1600	25.5	11.5	3200	24.1	24.2
	62.1	C28	28	1600	28.3	10.3	3200	27.4	21.2
	55.2	C32	31.5	1600	32.5	9.0	3200	31.8	18.3
	49.0	C36	35.5	1700	36.5	8.5	3200	34.7	16.8
	43.5	C40	40	1700	38.7	8.0	3200	39.0	15.0
	38.7	C45	45	1700	44.4	7.0	3200	42.7	13.6
	34.8	C50	50	1700	50.0	6.2	3200	49.4	11.8
	31.1	C56	56	1700	55.6	5.6	3200	56.6	10.3
	27.6	C63	63	1700	63.8	4.86	3200	61.3	9.5
24.5	C71	71	1700	71.7	4.32	3200	66.8	8.7	
21.8	C80	80	1700	80.2	3.86	3500	82.3	7.7	
19.3	C90	90	1700	89.3	3.47	3500	95.1	6.7	
17.4	D10	100	1700	97.8	3.17	3500	101.4	6.3	
15.5	D11	112	1700	106.4	2.91	3500	117.1	5.4	
13.9	D13	125	1700	119.6	2.59	3500	133.2	4.79	
12.4	D14	140	1700	131.0	2.36	3500	148.0	4.31	
10.9	D16	160	1700	153.8	2.01	3500	166.4	3.83	
9.7	D18	180	1700	170.9	1.81	3500	183.1	3.48	
8.70	D20	200	1700	188.0	1.65	3500	200.1	3.19	
7.77	D22	224	1700	212.0	1.46	3300	231.7	2.60	
6.96	D25	250	1700	249.4	1.24	3300	255.6	2.35	

Note:(1) Above the red line are two-stage transmission gearmotor models,model name F2...;
Below the red line are three-stage transmission gearmotor models,model name F3...;
(2) Actual output speed of the gearmotor:Actual input speed (n₁)/Exact ration (i_{ex});
(3) Rated input power corresponding to actual input speed of the gearmotor:P_{1N}=T_{2N}*n₁/ (9550*i_{ex}),the rated output torque T_{2N} in the formula remains unchanged.

Rated Output Torque	Exact Ratio	Rated Input Power	Rated Output Torque	Exact Ratio	Rated Input Power	Rated Output Torque	Exact Ratio	Rated Input Power	Rated Output Torque	Exact Ratio	Rated Input Power
T_{2N} (N·m)	i_{ex}	P_{1N} (kW)	T_{2N} (N·m)	i_{ex}	P_{1N} (kW)	T_{2N} (N·m)	i_{ex}	P_{1N} (kW)	T_{2N} (N·m)	i_{ex}	P_{1N} (kW)
F209 F309			F210 F310			F212 F312			F215 F315		
3000	3.97	138									
3000	4.68	117									
3200	5.08	115	4300	5.04	155	7000	4.88	262			
3400	5.93	104	4300	5.72	137	7500	5.43	252			
3600	6.57	100	4500	6.67	123	7500	6.11	224	16000	6.28	464
3600	7.10	92	4500	7.41	111	8500	7.04	220	16000	7.08	412
4000	7.95	92	5000	7.74	118	8500	7.77	199	16000	8.18	356
4000	9.37	78	5000	8.78	104	9000	8.61	190	18000	9.33	351
4500	10.2	81	5000	10.2	89	10000	9.58	190	18000	10.0	328
4500	11.9	69	5500	11.4	88	10000	10.9	168	18000	10.8	303
4500	13.2	62	5500	12.7	79	11000	12.4	162	18000	12.5	262
4500	13.9	59	6000	14.0	78	11000	13.7	147	19000	14.0	248
4700	15.9	54	6000	15.2	72	11000	15.1	133	19000	15.7	220
4700	17.7	48.3	6000	17.5	63	11000	16.8	119	19000	17.4	199
4700	19.7	43.5	6000	19.8	55	12000	19.1	114	19000	19.6	177
4700	22.4	38.2	7000	22.0	58	12000	21.2	103	20000	21.7	168
4700	24.0	35.7	7500	24.4	56	12000	24.3	90	20000	24.2	150
4700	27.4	31.2	8200	27.7	54	12000	27.6	79	20000	27.1	135
4700	30.5	28.1	8200	32.6	45.8	12000	32.2	68	20000	30.1	121
4700	33.9	25.2	8200	35.4	42.2	12000	35.7	61	20000	34.0	107
4700	40.1	21.4	8200	41.3	36.2	12000	39.8	55	20000	39.1	93
4700	44.9	19.1	8200	45.8	32.6	12000	44.0	49.7	20000	43.2	84
4700	48.0	17.8	8200	50.1	29.9	12000	48.5	45.1	20000	47.8	76
4700	54.9	15.6	8200	54.3	27.5	12000	56.5	38.7	20000	53.2	68
4700	61.0	14.0	8200	63.4	23.6	12000	62.8	34.8	20000	61.7	59
4700	69.2	12.4	8200	70.3	21.3	12000	70.0	31.3	20000	68.3	53
4700	77.6	11.0	8200	74.5	20.0	12000	77.3	28.3	20000	76.0	47.9
4700	88.5	9.7	8200	84.7	17.6	12000	83.8	26.1	20000	86.3	42.2
4700	94.4	9.1	8200	94.8	15.8	12000	96.4	22.7	20000	95.8	38.0
4700	108.4	7.9	8200	105.2	14.2	12000	109.2	20.0	20000	108.8	33.5
4700	122.0	7.0	8200	123.2	12.1	12000	121.5	18.0	20000	124.9	29.2
4700	134.7	6.4	8200	132.4	11.3	12000	134.5	16.3	20000	141.3	25.8
4700	151.5	5.7	8200	148.9	10.0	12000	157.0	13.9	20000	155.1	23.5
4700	175.5	4.88	8200	171.3	8.7	12000	166.6	13.1	20000	171.3	21.3
4700	193.9	4.42	8200	190.6	7.8	10000	188.9	9.6			
4700	218.0	3.93	8200	224.2	6.7	10000	215.6	8.5			
4700	237.2	3.61									

4.2 F.../C... Combi-type transmission capacity

F.../C...(i_N=125–18000)

Nominal Input Speed	Nominal Output Speed	Nominal Ratio Code	Nominal Ratio	Rated Output Torque	Exact Ratio	Rated Input Power	Rated Output Torque	Exact Ratio	Rated Input Power	
n _{1N} (r/min)	n _{2N} (r/min)	Code	i _N	T _{2N} (N·m)	i _{ex}	P _{1N} (kW)	T _{2N} (N·m)	i _{ex}	P _{1N} (kW)	
1740	13.92	D13	125	150	124.0	0.22	240	124.0	0.35	
	12.43	D14	140	150	146.4	0.19	240	146.4	0.30	
	10.88	D16	160	150	163.2	0.17	240	163.2	0.27	
	9.67	D18	180	150	182.4	0.15	240	182.4	0.24	
	8.70	D20	200	150	193.6	0.14	240	193.6	0.23	
								F303/C201		
	7.77	D22	224	150	224.8		240	224.1	0.20	
	6.96	D25	250	150	238.7		240	238.0	0.18	
	6.21	D28	280	150	270.5		240	269.7	0.16	
	5.52	D32	315	150	319.3		240	318.4	0.14	
	4.90	D36	355	150	356.0		240	355.0	0.12	
	4.35	D40	400	150	397.9		240	396.7		
	3.87	D45	450	150	422.3		240	421.1		
								F302/C301		
	3.48	D50	500	150	502.6		240	501.1		
	3.11	D56	560	150	575.9		240	574.2		
	2.76	D63	630	150	656.1		240	654.2		
	2.45	D71	710	150	712.0		240	709.9		
	2.18	D80	800	150	774.8		240	772.6		
	1.93	D90	900	150	858.5		240	856.1		
	1.74	E10	1000	150	959.8		240	957		
	1.55	E11	1120	150	1127		240	1124		
	1.39	E13	1250	150	1235		240	1232		
	1.24	E14	1400	150	1340		240	1336		
	1.09	E16	1600	150	1616		240	1611		
	0.97	E18	1800	150	1808		240	1803		
	0.87	E20	2000	150	1920		240	1914		
	0.78	E22	2240	150	2184		240	2234		
	0.70	E25	2500	150	2369		240	2423		
	0.62	E28	2800	150	2857		240	2922		
	0.55	E32	3150	150	3196		240	3269		
	0.49	E36	3550	150	3394		240	3471		
0.44	E40	4000	150	3751		240	3836			
0.39	E45	4500	150	4399		240	4499			
0.35	E50	5000	150	4998		240	5111			
0.31	E56	5600	150	5393		240	5515			
0.28	E63	6300	150	6438		240	6431			
0.25	E71	7100	150	7314		240	7306			
0.22	E80	8000	150	7892		240	7883			
0.19	E90	9000								
0.17	F10	10000								
0.16	F11	11200								
0.14	F13	12500								
0.12	F14	14000								
0.11	F16	16000								
0.10	F18	18000								

Rated Output Torque	Exact Ratio	Rated Input Power	Rated Output Torque	Exact Ratio	Rated Input Power	Rated Output Torque	Exact Ratio	Rated Input Power
T_{2N} (N·m)	i_{ex}	P_{IN} (kW)	T_{2N} (N·m)	i_{ex}	P_{IN} (kW)	T_{2N} (N·m)	i_{ex}	P_{IN} (kW)
F204/C203			F205/C203			F306/C203		
410	136.2	0.55	650	138.0	0.86			
410	156.1	0.48	650	158.1	0.75	900	156.1	1.05
410	171.4	0.44	650	173.6	0.68	900	171.4	0.96
410	192.8	0.39	650	195.3	0.61	900	192.8	0.85
F304/C203			F305/C203					
480	216.1	0.40	700	221.2	0.58	900	228.8	0.72
480	242.8	0.36	700	248.5	0.51	900	257.0	0.64
480	274.3	0.32	700	280.7	0.45	900	290.3	0.56
480	304.4	0.29	700	311.5	0.41	900	322.2	0.51
480	348.8	0.25	700	357.0	0.36	900	369.2	0.44
480	383.0	0.23	700	392.0	0.33	900	405.4	0.40
480	430.9	0.20	700	441.0	0.29	900	456.1	0.36
480	461.7	0.19	700	472.5	0.27	900	488.7	0.34
F304/C303			F305/C303			F306/C303		
480	523.3	0.17	700	535.5	0.24	900	553.9	0.30
480	591.7	0.15	700	605.5	0.21	900	626.3	0.26
480	673.7	0.13	700	689.5	0.18	900	713.1	0.23
480	759.2		700	777.0	0.16	900	803.6	0.20
480	861.8		700	882.0	0.14	900	912.2	0.18
480	920.0		700	941.5		900	973.8	0.17
480	1036		700	1061		900	1097	0.15
480	1180		700	1208		900	1249	0.13
480	1337		700	1369		900	1415	
480	1512		700	1547		900	1600	
480	1628		700	1666		900	1723	
480	1905		700	1950		900	2016	
430	2091		700	2139		900	2132	
430	2369		700	2424		900	2416	
430	2679		700	2740		900	2732	
430	2885		700	2951		900	2942	
430	3375		700	3453		900	3442	
430	3830		700	3918		900	3906	
430	4218		700	4315		900	4301	
430	4612		700	4718		900	4703	
430	5042		700	5158		900	5142	
430	5986		700	6041		900	5979	
430	6545		700	6605		900	6537	
430	7155		700	7222		900	7147	

F.../C... Combi-type transmission capacity

F.../C...(i_N=125-18000)

Nominal Input Speed	Nominal Output Speed	Nominal Ratio Code	Nominal Ratio	Rated Output Torque	Exact Ratio	Rated Input Power	Rated Output Torque	Exact Ratio	Rated Input Power	Rated Output Torque	Exact Ratio	Rated Input Power	
n _{1N} (r/min)	n _{2N} (r/min)	Code	i _N	T _{2N} (N·m)	i _{ex}	P _{1N} (kW)	T _{2N} (N·m)	i _{ex}	P _{1N} (kW)	T _{2N} (N·m)	i _{ex}	P _{1N} (kW)	
1740	13.92	D13	125										
	12.43	D14	140										
	10.88	D16	160	1550	164.2	1.72	3100	143.9	3.92	4700	153.6	5.6	
	9.67	D18	180	1550	180.3	1.57	3100	160.9	3.51	4700	171.7	4.99	
	8.70	D20	200	1550	202.9	1.39	3100	178.8	3.16	4700	190.8	4.49	
					F307/C203			F208/C205			F209/C205		
	7.77	D22	224	1700	230.7	1.34	3200	226.2	2.58	4700	221.0	3.87	
	6.96	D25	250	1700	259.2	1.20	3200	251.6	2.32	4700	245.8	3.48	
	6.21	D28	280	1700	292.7	1.06	3200	276.9	2.11	4700	270.5	3.17	
	5.52	D32	315	1700	324.9	0.95	3200	314.4	1.85	4700	307.1	2.79	
	4.90	D36	355	1700	372.3	0.83	3200	335.2	1.74	4700	327.5	2.61	
	4.35	D40	400	1700	408.8	0.76	3200	374.8	1.56	4700	366.1	2.34	
	3.87	D45	450	1700	459.9	0.67	3200	416.4	1.40	4700	406.8	2.11	
	3.48	D50	500	1700	492.8	0.63	3200	520.5	1.12	4700	508.5	1.68	
					F307/C303			F308/C205			F309/C205		
	3.11	D56	560	1700	558.5	0.55	3200	569.1	1.02	4700	556.0	1.54	
	2.76	D63	630	1700	631.5	0.49	3200	648.9	0.90	4700	633.9	1.35	
	2.45	D71	710	1700	719.1	0.43	3200	690.5	0.84	4700	674.6	1.27	
					F308/C305			F309/C305					
	2.18	D80	800	1700	810.3	0.38	3200	777.3	0.75	4700	759.4	1.13	
	1.93	D90	900	1700	919.8	0.34	3200	874.4	0.67	4700	854	1.00	
	1.74	E10	1000	1700	982	0.32	3200	985	0.59	4700	963	0.89	
	1.55	E11	1120	1700	1106	0.28	3200	1093	0.53	4700	1068	0.80	
	1.39	E13	1250	1700	1259	0.25	3200	1253	0.47	4700	1224	0.70	
	1.24	E14	1400	1700	1427	0.22	3200	1378	0.42	4700	1346	0.64	
	1.09	E16	1600	1700	1613	0.19	3200	1634	0.36	4700	1597	0.54	
	0.97	E18	1800	1700	1737	0.18	3200	1815	0.32	4700	1773	0.48	
	0.87	E20	2000	1700	2033	0.15	3200	2079	0.28	4700	2031	0.42	
	0.78	E22	2240	1700	2201		3200	2213	0.26	4700	2202	0.39	
	0.70	E25	2500	1700	2495		3200	2434	0.24	4700	2422	0.35	
	0.62	E28	2800	1700	2820		3200	2887	0.20	4700	2873	0.30	
	0.55	E32	3150	1700	3037		3200	3206	0.18	4700	3190	0.27	
	0.49	E36	3550	1700	3554		3200	3672	0.16	4700	3654	0.23	
	0.44	E40	4000	1700	4032		3200	4034	0.14	4700	4014	0.21	
	0.39	E45	4500	1700	4440		3200	4548	0.13	4700	4526	0.19	
	0.35	E50	5000	1700	4855		3200	4861		4700	4837	0.18	
	0.31	E56	5600	1700	5308		3200	5652		4700	5624	0.15	
	0.28	E63	6300	1700	6215		3500	7056		4700	6567		
	0.25	E71	7100	1700	6796		3500	7541		4700	7018		
	0.22	E80	8000	1700	7430		3500	8768		4700	8160		
	0.19	E90	9000				3500	9862		4700	9177		
	0.17	F10	10000				3500	10775		4700	10027		
0.16	F11	11200				3500	11811		4700	10992			
0.14	F13	12500				3500	12839		4700	11948			
0.12	F14	14000											
0.11	F16	16000											
0.10	F18	18000											

Rated Output Torque	Exact Ratio	Rated Input Power	Rated Output Torque	Exact Ratio	Rated Input Power	Rated Output Torque	Exact Ratio	Rated Input Power
T_{2N} (N·m)	i_{ex}	P_{IN} (kW)	T_{2N} (N·m)	i_{ex}	P_{IN} (kW)	T_{2N} (N·m)	i_{ex}	P_{IN} (kW)
F210/C207			F212/C208			F215/C209		
6000	156.6	7.0	11000	157.0	12.8	19000	158.6	21.8
6000	176.3	6.2	11000	170.6	11.7	19000	179.0	19.3
F310/C207			F312/C207			F315/C209		
8200	199.7	7.5	11000	191.8	10.5	19000	190.0	18.2
8200	224.4	6.7	12000	226.3	9.7	20000	210.1	17.3
8200	252.8	5.9	12000	254.9	8.6	20000	240.0	15.2
8200	287.8	5.2	12000	290.2	7.5	20000	266.9	13.7
8200	319.0	4.68	12000	321.7	6.8	20000	302.9	12.0
8200	364.6	4.10	12000	367.7	5.9	20000	343.4	10.6
8200	410.6	3.64	12000	414.1	5.3	20000	387.6	9.4
F310/C307			F312/C307			F315/C309		
8200	446.0	3.35	12000	449.8	4.86	20000	411.4	8.9
8200	513.3	2.91	12000	517.7	4.22	20000	472.6	7.7
8200	545.2	2.74	12000	549.8	3.98	20000	523.6	7.0
8200	626.6	2.38	12000	631.9	3.46	20000	595.0	6.1
8200	732.8	2.04	12000	739.0	2.96	20000	666.4	5.5
8200	821.3	1.82	12000	828.2	2.64	20000	761.6	4.78
8200	938.1	1.59	12000	946.1	2.31	20000	812.6	4.48
F310/C309			F312/C309			F315/C309		
8200	1002	1.49	12000	1010	2.16	20000	948.6	3.84
8200	1147	1.30	12000	1157	1.89	20000	1098	3.32
8200	1306	1.14	12000	1317	1.66	20000	1197	3.04
8200	1345	1.11	12000	1357	1.61	20000	1346	2.71
8200	1543	0.97	12000	1557	1.40	20000	1476	2.47
8200	1752	0.85	12000	1767	1.24	20000	1703	2.14
8200	1961	0.76	12000	1978	1.11	20000	1819	2.00
8200	2339	0.64	12000	2317	0.94	20000	2172	1.68
8200	2409	0.62	12000	2386	0.92	20000	2443	1.49
8200	2764	0.54	12000	2738	0.80	20000	2678	1.36
8200	3138	0.48	12000	3109	0.70	20000	3091	1.18
8200	3512	0.43	12000	3479	0.63	20000	3301	1.10
8200	3912	0.38	12000	3875	0.56	20000	3912	0.93
8200	4299	0.35	12000	4258	0.51	20000	4263	0.85
8200	4882	0.31	12000	4836	0.45	20000	4800	0.76
8200	6074	0.25	12000	6016	0.36	20000	5257	0.69
8200	5743	0.26	12000	5682	0.38	20000	5963	0.61
8200	6522	0.23	12000	6453	0.34	20000	6714	0.54
8200	8114	0.18	12000	8028	0.27	20000	7353	0.50
8200	8622	0.17	12000	8531	0.26	20000	8501	0.43
8200	9969	0.15	12000	9863	0.22	20000	9062	0.40
8200	10545	0.14	12000	10433	0.21	20000	10468	0.35
8200	11858	0.13	12000	11732	0.19	20000	11901	0.31
8200	12612		12000	12478	0.18	20000	13221	0.28
8200	14247		12000	14095	0.16	20000	14869	0.25
						20000	16362	0.22

5 Permissible Radial Force

5.1 Radial force on input shaft (Fr1) (N)

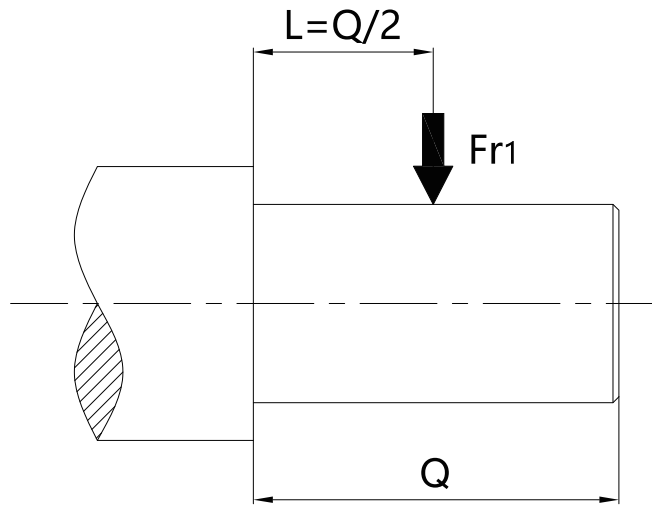

	Fr1 (N)										
	F202 F302	F203 F303	F204 F304	F205 F305	F206 F306	F207 F307	F208 F308	F209 F309	F210 F310	F212 F312	F215 F315
AE2	803	803	803	803	803	803	803	/	/	/	/
AE3	/	/	/	1504	1504	1504	1504	1504	1504	/	/
AE4	/	/	/	/	/	2188	2188	2188	2188	2188	/
AE5	/	/	/	/	/	/	4207	4207	4207	4207	4207
AE6	/	/	/	/	/	/	/	5664	5664	5664	5664
AE7	/	/	/	/	/	/	/	/	/	9957	9957
AE8	/	/	/	/	/	/	/	/	/	12546	12546

5.2 Radial force on output shaft (Fr2) (N)

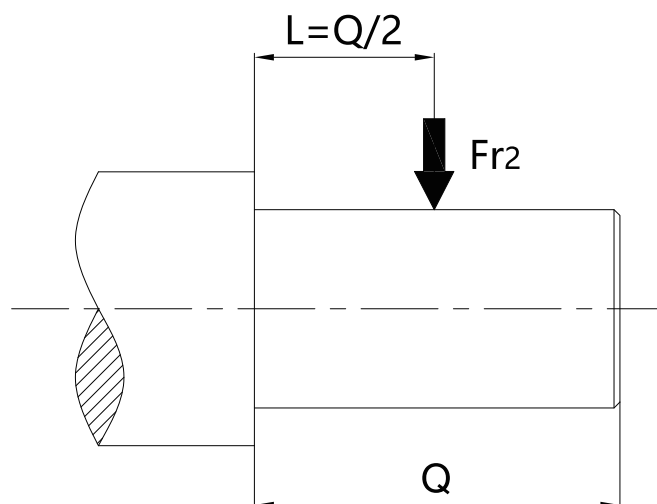

n _{2N} (r/min)	Fr2 (N)										
	F202 F302	F203 F303	F204 F304	F205 F305	F206 F306	F207 F307	F208 F308	F209 F309	F210 F310	F212 F312	F215 F315
315~425	1281	1827	2079	3986	7641	9140	9210	9380	/	/	/
280~315	1334	1908	2115	4104	7965	9320	9480	9540	14000	28530	/
224~280	1378	1971	2151	4220	8280	9510	9770	10080	15300	28800	29050
200~224	1423	2043	2223	4396	8694	9700	10060	10080	18990	28980	29640
180~200	1448	2115	2277	4549	9090	9890	10360	10530	20880	33300	30250
160~180	1478	2115	2646	5095	9810	10090	10670	11520	21600	32760	30850
140~160	1548	2214	2925	5478	10260	10290	11000	12240	22500	31500	31450
125~140	1623	2322	3096	5357	9270	10500	11320	12240	20610	30600	33150
112~125	1695	2475	3366	5586	9270	10710	11660	12250	21870	32760	37350
100~112	1745	2547	3555	5741	9270	10920	12010	13000	22050	32760	38250
90~100	1892	2763	3888	6003	9270	11140	12370	13760	22700	33840	40410
80~90	1961	2862	4005	6093	9270	11370	12740	14590	24300	36000	42300
71~80	2090	3051	4293	6308	9270	11600	13130	15460	25290	37800	45810
63~71	2157	3150	4527	6478	9270	11820	13520	16400	27000	37800	45900
56~63	2410	3519	4923	6755	9270	12060	13930	17380	28980	48600	55350
45~56	2503	3654	5247	6974	9270	12300	14340	18420	30330	42750	54720
40~45	2644	3861	5328	7028	9270	12550	14770	19520	34470	47340	71370
35.5~40	2644	3861	5328	7028	9270	12800	15220	23400	35550	49320	74070
31.5~35.5	2644	3861	5328	7028	9270	13050	15670	21240	37800	52110	79020
28~31.5	2644	3861	5328	7028	9270	13320	16150	23220	39150	55620	83520
25~28	2644	3861	5328	7028	9270	13580	16630	23220	41820	58770	88470
22.4~25	2644	3861	5328	7028	9270	13850	17130	26100	43020	60660	74250
≤22.4	2644	3861	5328	7028	9270	14130	17640	26910	44820	63450	78300

6 Dimensions

Mounting Mode	F202/F302 Dimensions				
Horizontal foot-mounted					
	<p>F202HA Unidirectional output shaft F302HA Unidirectional output shaft F202HC Bidirectional output shaft F302HC Bidirectional output shaft</p>	<p>F202HG Hollow shaft with parallel key F302HG Hollow shaft with parallel key</p>	<p>F202HI Hollow shaft with shrink disk F302HI Hollow shaft with shrink disk</p>	<p>F202HK Hollow shaft with involute spline F302HK Hollow shaft with involute spline</p>	<p>Horizontal foot-mounted (H) Weight:9kg (Without motor and oil)</p>
Flange-mounted					
	<p>F202FA Unidirectional output shaft F302FA Unidirectional output shaft F202FC Bidirectional output shaft F302FC Bidirectional output shaft</p>	<p>F202FG Hollow shaft with parallel key F302FG Hollow shaft with parallel key</p>	<p>F202FI Hollow shaft with shrink disk F302FI Hollow shaft with shrink disk</p>	<p>F202FK Hollow shaft with involute spline F302FK Hollow shaft with involute spline</p>	<p>Flange-mounted (F) Weight:12kg (Without motor and oil)</p>
Short flange-mounted					
		<p>F202SG Hollow shaft with parallel key F302SG Hollow shaft with parallel key</p>	<p>F202SI Hollow shaft with shrink disk F302SI Hollow shaft with shrink disk</p>	<p>F202SK Hollow shaft with involute spline F302SK Hollow shaft with involute spline</p>	<p>Short flange-mounted (S) Weight:10kg (Without motor and oil)</p>
Torque arm-mounted					
Torque arm-mounted with accessory		<p>F202AG Hollow shaft with parallel key F302AG Hollow shaft with parallel key F202TG Hollow shaft with parallel key F302TG Hollow shaft with parallel key</p>	<p>F202AI Hollow shaft with shrink disk F302AI Hollow shaft with shrink disk F202TI Hollow shaft with shrink disk F302TI Hollow shaft with shrink disk</p>	<p>F202AK Hollow shaft with involute spline F302AK Hollow shaft with involute spline F202TK Hollow shaft with involute spline F302TK Hollow shaft with involute spline</p>	<p>Torque arm-mounted (A) Weight:10kg (Without motor and oil) Torque arm-mounted with accessory (T) Weight:10kg (Without motor and oil)</p>

Note:Involute spline size DIN 5480 : m1.25 × X18 × α 30 × D25 × 9H

Corresponding motor dimension table for F202/F302

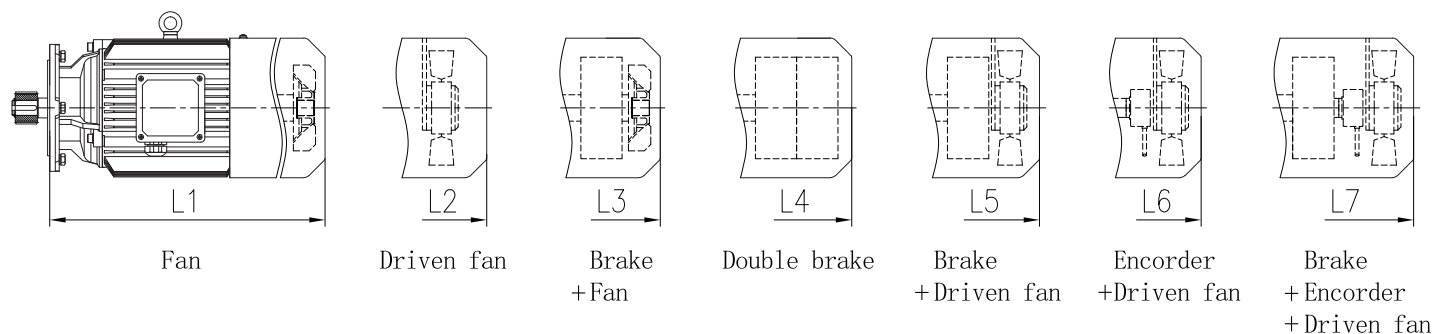

Directly connected motor dimension table

4-pole power (kW)	Range of Ratio	MA						D
		L1	L2	L3	L5	L6	L7	
0.12	4-112	206	261	241	296	*	*	124
0.18	4-112	206	261	241	296	*	*	124
0.25	4-112	223	273	263	318	318	358	139
0.37	4-71	223	273	263	318	318	358	139
0.55	4-50	299	344	359	404	404	449	162
0.75	4-35.5	299	344	359	404	404	449	162
1.1	4-25	347	392	402	452	452	497	176
1.5	4-18	347	392	402	452	452	497	176

Directly connected motor weight table / kg

4-pole power (kW)	Range of Ratio	MA						
		M1	M2	M3	M5	M6	M7	
0.12	4-112	7	7.5	8.5	9	/	/	
0.18	4-112	8	8.5	9.5	10	/	/	
0.25	4-112	9	10	10.5	11.5	10.5	12.5	
0.37	4-71	10	11	11.5	12.5	11.5	13.5	
0.55	4-50	15	16	19	20	16.5	21	
0.75	4-35.5	16	17	20	21	17.5	22	
1.1	4-25	21	22	25	26	22.5	27	
1.5	4-18	23	24	27	28	24.5	29	

Mounting Mode	F203/F303 Dimensions					
Horizontal foot-mounted						<p>F203HA Unidirectional output shaft F303HA Unidirectional output shaft F203HC Bidirectional output shaft F303HC Bidirectional output shaft</p> <p>F203HG Hollow shaft with parallel key F303HG Hollow shaft with parallel key</p> <p>F203HI Hollow shaft with shrink disk F303HI Hollow shaft with shrink disk</p> <p>F203HK Hollow shaft with involute spline F303HK Hollow shaft with involute spline</p> <p>Horizontal foot-mounted (H) Weight: 13kg (Without motor and oil)</p>
Flange-mounted						<p>F203FA Unidirectional output shaft F303FA Unidirectional output shaft F203FC Bidirectional output shaft F303FC Bidirectional output shaft</p> <p>F203FG Hollow shaft with parallel key F303FG Hollow shaft with parallel key</p> <p>F203FI Hollow shaft with shrink disk F303FI Hollow shaft with shrink disk</p> <p>F203FK Hollow shaft with involute spline F303FK Hollow shaft with involute spline</p> <p>Flange-mounted (F) Weight: 16kg (Without motor and oil)</p>
Short flange-mounted						<p>F203SG Hollow shaft with parallel key F303SG Hollow shaft with parallel key</p> <p>F203SI Hollow shaft with shrink disk F303SI Hollow shaft with shrink disk</p> <p>F203SK Hollow shaft with involute spline F303SK Hollow shaft with involute spline</p> <p>Short flange-mounted (S) Weight: 14kg (Without motor and oil)</p>
Torque arm-mounted						<p>F203AG Hollow shaft with parallel key F303AG Hollow shaft with parallel key F203TG Hollow shaft with parallel key F303TG Hollow shaft with parallel key</p> <p>F203AI Hollow shaft with shrink disk F303AI Hollow shaft with shrink disk F203TI Hollow shaft with shrink disk F303TI Hollow shaft with shrink disk</p> <p>F203AK Hollow shaft with involute spline F303AK Hollow shaft with involute spline F203TK Hollow shaft with involute spline F303TK Hollow shaft with involute spline</p> <p>Torque arm-mounted (A) Weight: 10kg (Without motor and oil)</p> <p>Torque arm-mounted with accessory (T) Weight: 10kg (Without motor and oil)</p>

Note: Involute spline size DIN 5480: m1.25 × Z22 × α 30 × D30 × 9H

Corresponding motor dimension table for F203/F303

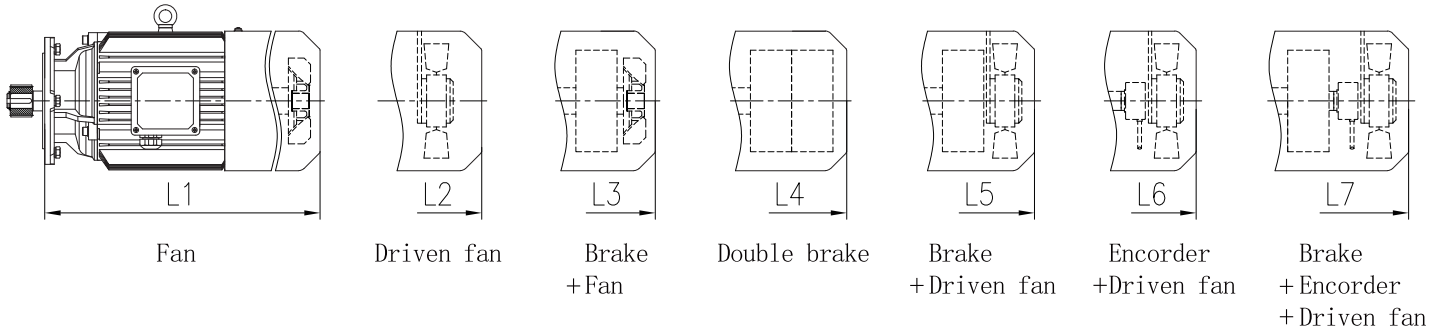

Directly connected motor dimension table

4-pole power (kW)	Range of Ratio	MA						D
		L1	L2	L3	L5	L6	L7	
0.12	4-125	206	261	241	296	*	*	124
0.18	4-125	206	261	241	296	*	*	124
0.25	4-125	223	273	263	318	318	358	139
0.37	4-125	223	273	263	318	318	358	139
0.55	4-80	299	344	359	404	404	449	162
0.75	4-56	299	344	359	404	404	449	162
1.1	4-40	347	392	402	452	452	497	176
1.5	4-28	347	392	402	452	452	497	176
2.2	4-20	394	449	469	529	529	574	202
3	4-14	394	449	469	529	529	574	202

Directly connected motor weight table / kg

4-pole power (kW)	Range of Ratio	MA						
		M1	M2	M3	M5	M6	M7	
0.12	4-125	7	7.5	8.5	9	/	/	
0.18	4-125	8	8.5	9.5	10	/	/	
0.25	4-125	9	10	10.5	11.5	10.5	12.5	
0.37	4-125	10	11	11.5	12.5	11.5	13.5	
0.55	4-80	15	16	19	20	16.5	21	
0.75	4-56	16	17	20	21	17.5	22	
1.1	4-40	21	22	25	26	22.5	27	
1.5	4-28	23	24	27	28	24.5	29	
2.2	4-20	36	37	44	45	38	45	
3	4-14	36	37	44	45	38	45	

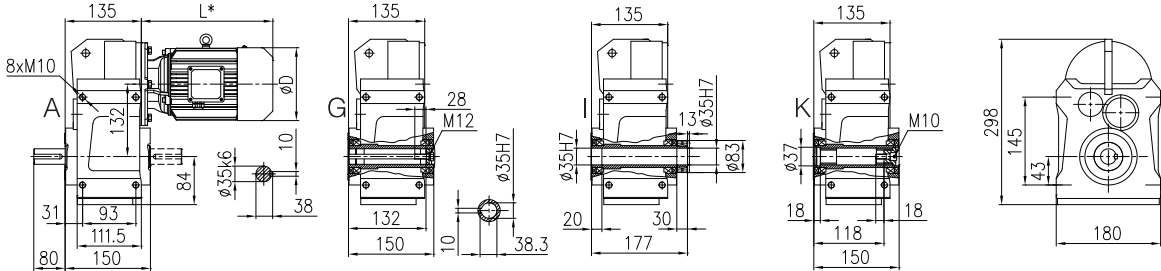
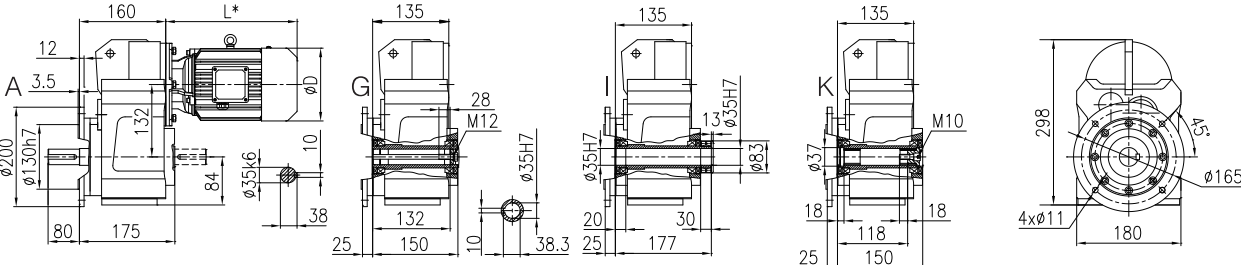
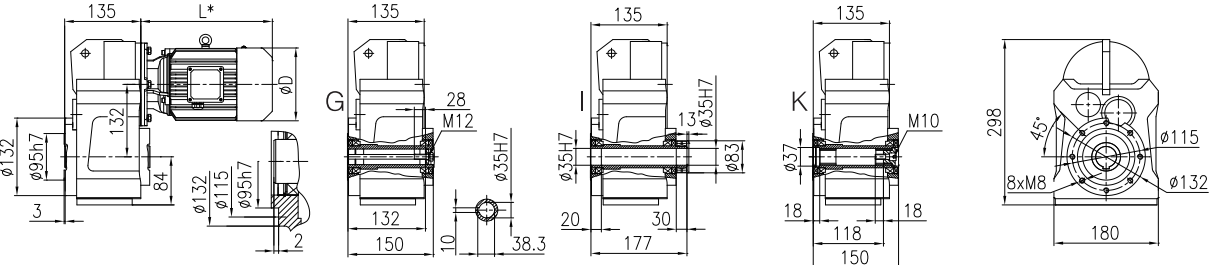
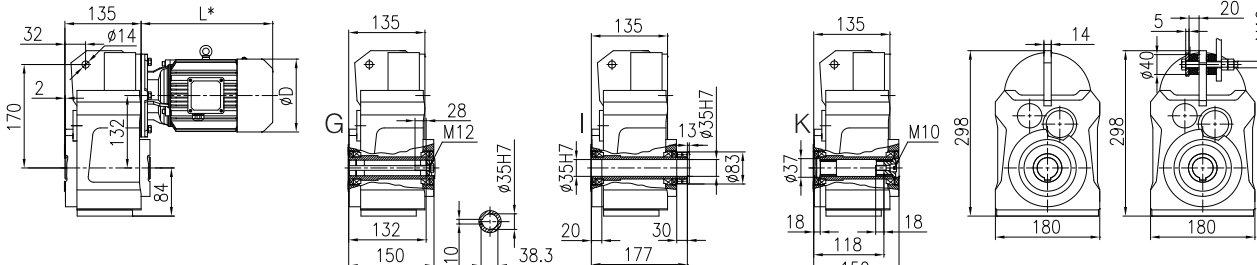
Mounting Mode	F204/F304 Dimensions				
Horizontal foot-mounted					
	F204HA Unidirectional output shaft F304HA Unidirectional output shaft F204HC Bidirectional output shaft F304HC Bidirectional output shaft	F204HG Hollow shaft with parallel key F304HG Hollow shaft with parallel key	F204HI Hollow shaft with shrink disk F304HI Hollow shaft with shrink disk	F204HK Hollow shaft with involute spline F304HK Hollow shaft with involute spline	Horizontal foot-mounted (H) Weight:16kg (Without motor and oil)
Flange-mounted					
	F204FA Unidirectional output shaft F304FA Unidirectional output shaft F204FC Bidirectional output shaft F304FC Bidirectional output shaft	F204FG Hollow shaft with parallel key F304FG Hollow shaft with parallel key	F204FI Hollow shaft with shrink disk F304FI Hollow shaft with shrink disk	F204FK Hollow shaft with involute spline F304FK Hollow shaft with involute spline	Flange-mounted (F) Weight:20kg (Without motor and oil)
Short flange-mounted					
		F204SG Hollow shaft with parallel key F304SG Hollow shaft with parallel key	F204SI Hollow shaft with shrink disk F304SI Hollow shaft with shrink disk	F204SK Hollow shaft with involute spline F304SK Hollow shaft with involute spline	Short flange-mounted (S) Weight:17kg (Without motor and oil)
Torque arm-mounted					
Torque arm-mounted with accessory		F204AG Hollow shaft with parallel key F304AG Hollow shaft with parallel key F204TG Hollow shaft with parallel key F304TG Hollow shaft with parallel key	F204AI Hollow shaft with shrink disk F304AI Hollow shaft with shrink disk F204TI Hollow shaft with shrink disk F304TI Hollow shaft with shrink disk	F204AK Hollow shaft with involute spline F304AK Hollow shaft with involute spline F204TK Hollow shaft with involute spline F304TK Hollow shaft with involute spline	Torque arm-mounted (A) Weight:17kg (Without motor and oil)
				Torque arm-mounted with accessory (T) Weight:17kg (Without motor and oil)	

Note: Involute spline size DIN 5480: m2 × Z16 × α 30 × D35 × 9H

Corresponding motor dimension table for F204/F304

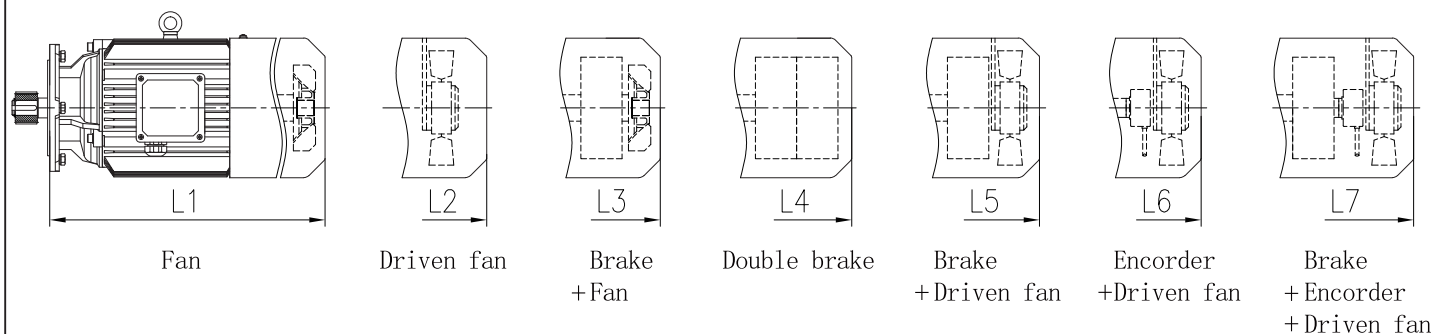

Directly connected motor dimension table

4-pole power (kW)	Range of Ratio	MA						D
		L1	L2	L3	L5	L6	L7	
0.12	4.5-160	207	262	242	297	*	*	124
0.18	4.5-160	207	262	242	297	*	*	124
0.25	4.5-160	224	274	264	319	319	359	139
0.37	4.5-160	224	274	264	319	319	359	139
0.55	4.5-140	300	345	360	405	405	450	162
0.75	4.5-112	300	345	360	405	405	450	162
1.1	4.5-71	348	393	403	453	453	498	176
1.5	4.5-50	348	393	403	453	453	498	176
2.2	4.5-40	395	450	470	530	530	575	202
3	4.5-28	395	450	470	530	530	575	202
4	4.5-20	459	519	534	599	599	639	220

Directly connected motor weight table / kg

4-pole power (kW)	Range of Ratio	MA						
		M1	M2	M3	M5	M6	M7	
0.12	4.5-160	7	7.5	8.5	9	/	/	
0.18	4.5-160	8	8.5	9.5	10	/	/	
0.25	4.5-160	9	10	10.5	11.5	10.5	12.5	
0.37	4.5-160	10	11	11.5	12.5	11.5	13.5	
0.55	4.5-140	15	16	19	20	16.5	21	
0.75	4.5-112	16	17	20	21	17.5	22	
1.1	4.5-71	21	22	25	26	22.5	27	
1.5	4.5-50	23	24	27	28	24.5	29	
2.2	4.5-40	36	37	44	45	38	45	
3	4.5-28	36	37	44	45	38	45	
4	4.5-20	56	57	64	65	58	66	

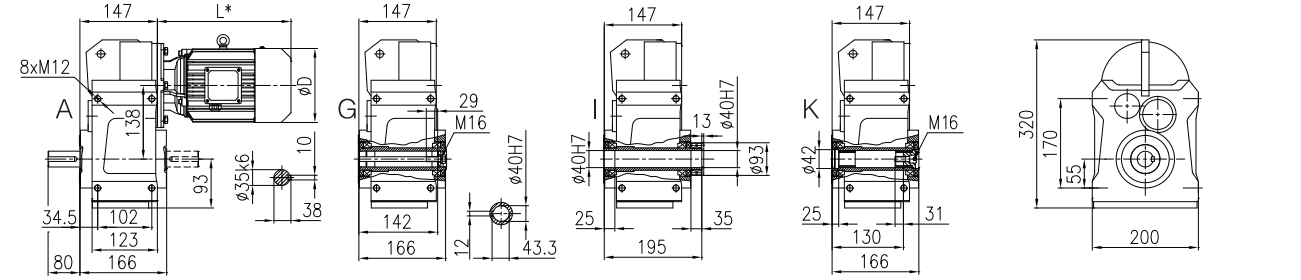
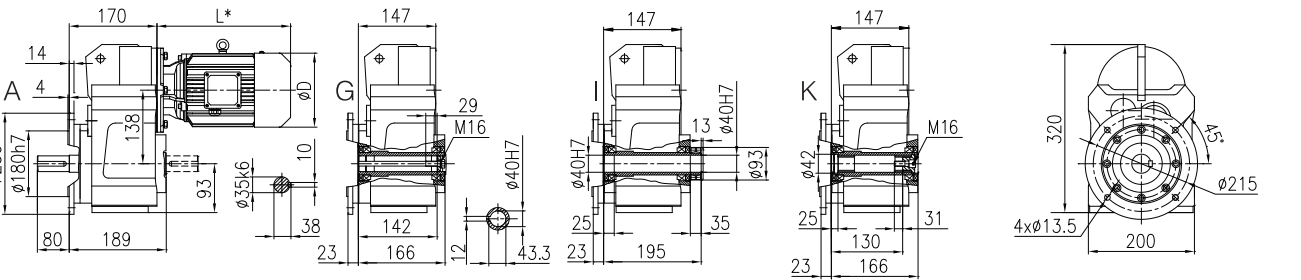
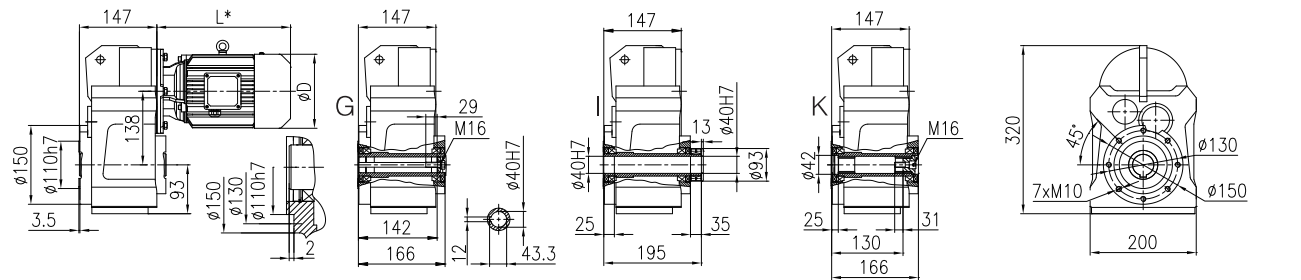
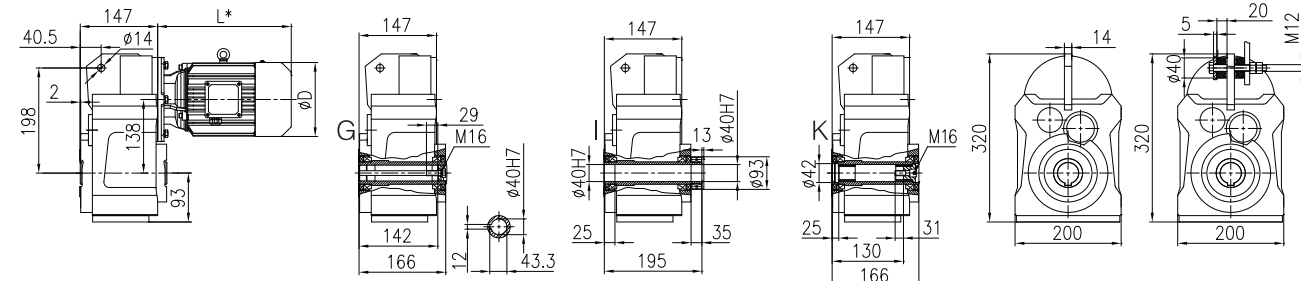
Mounting Mode	F205/F305 Dimensions				
Horizontal foot-mounted	 <p data-bbox="228 632 1518 721"> F205HA Unidirectional output shaft F305HA Unidirectional output shaft F205HC Bidirectional output shaft F305HC Bidirectional output shaft F205HG Hollow shaft with parallel key F305HG Hollow shaft with parallel key F205HI Hollow shaft with shrink disk F305HI Hollow shaft with shrink disk F205HK Hollow shaft with involute spline F305HK Hollow shaft with involute spline Horizontal foot-mounted (H) Weight:21kg (Without motor and oil) </p>				
Flange-mounted	 <p data-bbox="228 1066 1518 1154"> F205FA Unidirectional output shaft F305FA Unidirectional output shaft F205FC Bidirectional output shaft F305FC Bidirectional output shaft F205FG Hollow shaft with parallel key F305FG Hollow shaft with parallel key F205FI Hollow shaft with shrink disk F305FI Hollow shaft with shrink disk F205FK Hollow shaft with involute spline F305FK Hollow shaft with involute spline Flange-mounted (F) Weight:26kg (Without motor and oil) </p>				
Short flange-mounted	 <p data-bbox="472 1530 1518 1579"> F205SG Hollow shaft with parallel key F305SG Hollow shaft with parallel key F205SI Hollow shaft with shrink disk F305SI Hollow shaft with shrink disk F205SK Hollow shaft with involute spline F305SK Hollow shaft with involute spline Short flange-mounted (S) Weight:22kg (Without motor and oil) </p>				
Torque arm-mounted	 <p data-bbox="472 1948 1518 2026"> F205AG Hollow shaft with parallel key F305AG Hollow shaft with parallel key F205TI Hollow shaft with parallel key F305TI Hollow shaft with parallel key F205AI Hollow shaft with shrink disk F305AI Hollow shaft with shrink disk F205TI Hollow shaft with shrink disk F305TI Hollow shaft with shrink disk F205AK Hollow shaft with involute spline F305AK Hollow shaft with involute spline F205TK Hollow shaft with involute spline F305TK Hollow shaft with involute spline Torque arm-mounted (A) Weight:22kg (Without motor and oil) Torque arm-mounted with accessory (T) Weight:22kg (Without motor and oil) </p>				

Note: Involute spline size DIN 5480: m2 × Z16 × α30 × D35 × 9H

Corresponding motor dimension table for F205/F305

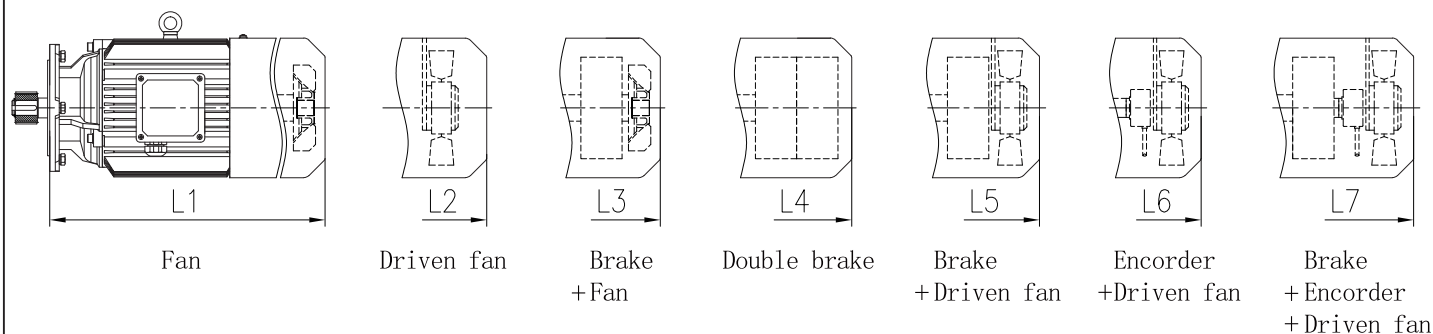

Directly connected motor dimension table

4-pole power (kW)	Range of Ratio	MA						D
		L1	L2	L3	L5	L6	L7	
0.25	4-140	224	274	264	319	319	359	139
0.37	4-140	224	274	264	319	319	359	139
0.55	4-140	300	345	360	405	405	450	162
0.75	4-140	300	345	360	405	405	450	162
1.1	4-80	348	393	403	453	453	498	176
1.5	4-80	348	393	403	453	453	498	176
2.2	4-56	395	450	470	530	530	575	202
3	4-45	395	450	470	530	530	575	202
4	4-31.5	459	519	534	599	599	639	220

Directly connected motor weight table / kg

4-pole power (kW)	Range of Ratio	MA						
		M1	M2	M3	M5	M6	M7	
0.25	4-140	9	10	10.5	11.5	10.5	12.5	
0.37	4-140	10	11	11.5	12.5	11.5	13.5	
0.55	4-140	15	16	19	20	16.5	21	
0.75	4-140	16	17	20	21	17.5	22	
1.1	4-80	21	22	25	26	22.5	27	
1.5	4-80	23	24	27	28	24.5	29	
2.2	4-56	36	37	44	45	38	45	
3	4-45	36	37	44	45	38	45	
4	4-31.5	56	57	64	65	58	66	

Mounting Mode	F206/F306 Dimensions				
Horizontal foot-mounted	<p> F206HA Unidirectional output shaft F306HA Unidirectional output shaft F206HC Bidirectional output shaft F306HC Bidirectional output shaft </p> <p> F206HG Hollow shaft with parallel key F306HG Hollow shaft with parallel key </p> <p> F206HI Hollow shaft with shrink disk F306HI Hollow shaft with shrink disk </p> <p> F206HK Hollow shaft with involute spline F306HK Hollow shaft with involute spline </p> <p>Horizontal foot-mounted (H) Weight: 30kg (Without motor and oil)</p>				
Flange-mounted	<p> F206FA Unidirectional output shaft F306FA Unidirectional output shaft F206FC Bidirectional output shaft F306FC Bidirectional output shaft </p> <p> F206FG Hollow shaft with parallel key F306FG Hollow shaft with parallel key </p> <p> F206FI Hollow shaft with shrink disk F306FI Hollow shaft with shrink disk </p> <p> F206FK Hollow shaft with involute spline F306FK Hollow shaft with involute spline </p> <p>Flange-mounted (F) Weight: 36kg (Without motor and oil)</p>				
Short flange-mounted	<p> F206SG Hollow shaft with parallel key F306SG Hollow shaft with parallel key </p> <p> F206SI Hollow shaft with shrink disk F306SI Hollow shaft with shrink disk </p> <p> F206SK Hollow shaft with involute spline F306SK Hollow shaft with involute spline </p> <p>Short flange-mounted (S) Weight: 32kg (Without motor and oil)</p>				
Torque arm-mounted	<p> F206AG Hollow shaft with parallel key F306AG Hollow shaft with parallel key F206TG Hollow shaft with parallel key F306TG Hollow shaft with parallel key </p> <p> F206AI Hollow shaft with shrink disk F306AI Hollow shaft with shrink disk F206TI Hollow shaft with shrink disk F306TI Hollow shaft with shrink disk </p> <p> F206AK Hollow shaft with involute spline F306AK Hollow shaft with involute spline F206TK Hollow shaft with involute spline F306TK Hollow shaft with involute spline </p> <p>Torque arm-mounted (A) Weight: 32kg (Without motor and oil)</p> <p>Torque arm-mounted with accessory (T) Weight: 32kg (Without motor and oil)</p>				

Note: Involute spline size DIN 5480: m2 × Z16 × α 30 × D35 × 9H

Corresponding motor dimension table for F206/F306

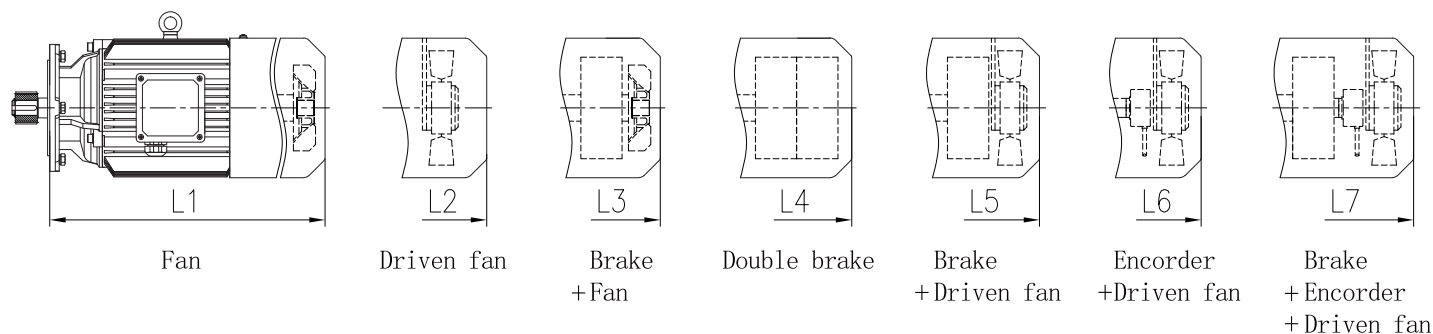

Directly connected motor dimension table

4-pole power (kW)	Range of Ratio	MA						D
		L1	L2	L3	L5	L6	L7	
0.25	140-200	224	274	264	319	319	359	139
0.37	100-200	224	274	264	319	319	359	139
0.55	63-200	300	345	360	405	405	450	162
0.75	45-200	300	345	360	405	405	450	162
1.1	31.5-112	348	393	403	453	453	498	176
1.5	25-112	348	393	403	453	453	498	176
2.2	16-80	395	450	470	530	530	575	202
3	9-56	395	450	470	530	530	575	202
4	6.3-40	459	519	534	599	599	639	220
5.5	4-28	508	573	588	658	658	688	259
7.5	4-22.4	508	573	588	658	658	688	259

Directly connected motor weight table / kg

4-pole power (kW)	Range of Ratio	MA						
		M1	M2	M3	M5	M6	M7	
0.25	140-200	9	10	10.5	11.5	10.5	12.5	
0.37	100-200	10	11	11.5	12.5	11.5	13.5	
0.55	63-200	15	16	19	20	16.5	21	
0.75	45-200	16	17	20	21	17.5	22	
1.1	31.5-112	21	22	25	26	22.5	27	
1.5	25-112	23	24	27	28	24.5	29	
2.2	16-80	36	37	44	45	38	45	
3	9-56	36	37	44	45	38	45	
4	6.3-40	56	57	64	65	58	66	
5.5	4-28	77	79	88	90	80	91	
7.5	4-22.4	88	90	99	101	91	102	

Mounting Mode	F207/F307 Dimensions				
Horizontal foot-mounted					
	<p>F207HA Unidirectional output shaft F307HA Unidirectional output shaft F207HC Bidirectional output shaft F307HC Bidirectional output shaft</p>	<p>F207HG Hollow shaft with parallel key F307HG Hollow shaft with parallel key</p>	<p>F207HI Hollow shaft with shrink disk F307HI Hollow shaft with shrink disk</p>	<p>F207HK Hollow shaft with involute spline F307HK Hollow shaft with involute spline</p>	<p>Horizontal foot-mounted (H) Weight:50kg (Without motor and oil)</p>
Flange-mounted					
	<p>F207FA Unidirectional output shaft F307FA Unidirectional output shaft F207FC Bidirectional output shaft F307FC Bidirectional output shaft</p>	<p>F207FG Hollow shaft with parallel key F307FG Hollow shaft with parallel key</p>	<p>F207FI Hollow shaft with shrink disk F307FI Hollow shaft with shrink disk</p>	<p>F207FK Hollow shaft with involute spline F307FK Hollow shaft with involute spline</p>	<p>Flange-mounted (F) Weight:60kg (Without motor and oil)</p>
Short flange-mounted					
		<p>F207SG Hollow shaft with parallel key F307SG Hollow shaft with parallel key</p>	<p>F207SI Hollow shaft with shrink disk F307SI Hollow shaft with shrink disk</p>	<p>F207SK Hollow shaft with involute spline F307SK Hollow shaft with involute spline</p>	<p>Short flange-mounted (S) Weight:52kg (Without motor and oil)</p>
Torque arm-mounted					
Torque arm-mounted with accessory		<p>F207AG Hollow shaft with parallel key F307AG Hollow shaft with parallel key F207TG Hollow shaft with parallel key F307TG Hollow shaft with parallel key</p>	<p>F207AI Hollow shaft with shrink disk F307AI Hollow shaft with shrink disk F207TI Hollow shaft with shrink disk F307TI Hollow shaft with shrink disk</p>	<p>F207AK Hollow shaft with involute spline F307AK Hollow shaft with involute spline F207TK Hollow shaft with involute spline F307TK Hollow shaft with involute spline</p>	<p>Torque arm-mounted (A) Torque arm-mounted with accessory (T) Weight:52kg Weight:52kg (Without motor and oil) (Without motor and oil)</p>

Note: Involute spline size DIN 5480: m2 × Z24 × α30 × D50 × 9H

Corresponding motor dimension table for F207/F307

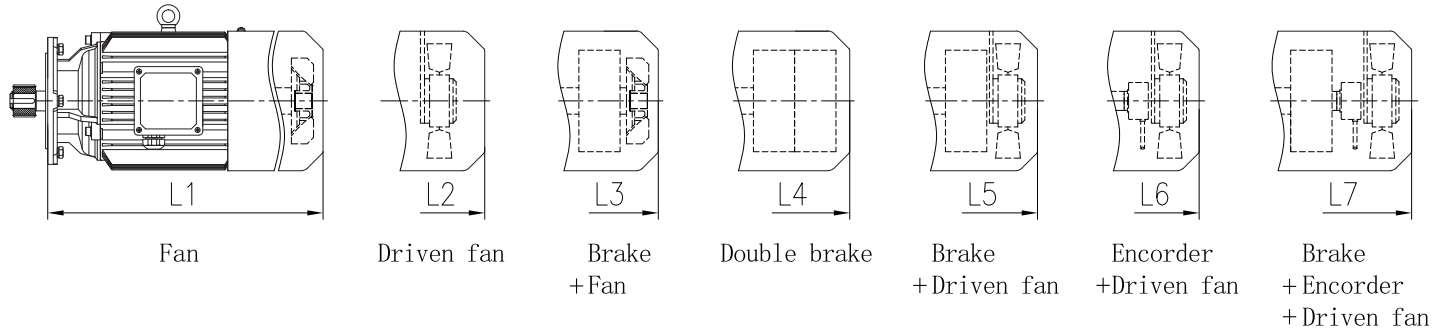

Directly connected motor dimension table

4-pole power (kW)	Range of Ratio	MA						D
		L1	L2	L3	L5	L6	L7	
0.37	180-250	216	266	256	311	311	351	139
0.55	125-250	292	337	352	397	397	442	162
0.75	90-250	292	337	352	397	397	442	162
1.1	63-160	340	385	395	445	445	490	176
1.5	45-160	340	385	395	445	445	490	176
2.2	28-140	387	442	462	522	522	567	202
3	20-112	387	442	462	522	522	567	202
4	14-80	451	511	526	591	591	631	220
5.5	6.3-56	497	562	577	647	647	677	259
7.5	4.5-40	497	562	577	647	647	677	259
11	4-25	551	601	646	701	701	736	314
15	4-20	581	631	676	731	731	766	314

Directly connected motor weight table / kg

4-pole power (kW)	Range of Ratio	MA					
		M1	M2	M3	M5	M6	M7
0.37	180-250	10	11	11.5	12.5	11.5	13.5
0.55	125-250	15	16	19	20	16.5	21
0.75	90-250	16	17	20	21	17.5	22
1.1	63-160	21	22	25	26	22.5	27
1.5	45-160	23	24	27	28	24.5	29
2.2	28-140	36	37	44	45	38	45
3	20-112	36	37	44	45	38	45
4	14-80	56	57	64	65	58	66
5.5	6.3-56	77	79	88	90	80	91
7.5	4.5-40	88	90	99	101	91	102
11	4-25	129	131	150	151	132	152
15	4-20	161	163	182	183	164	184

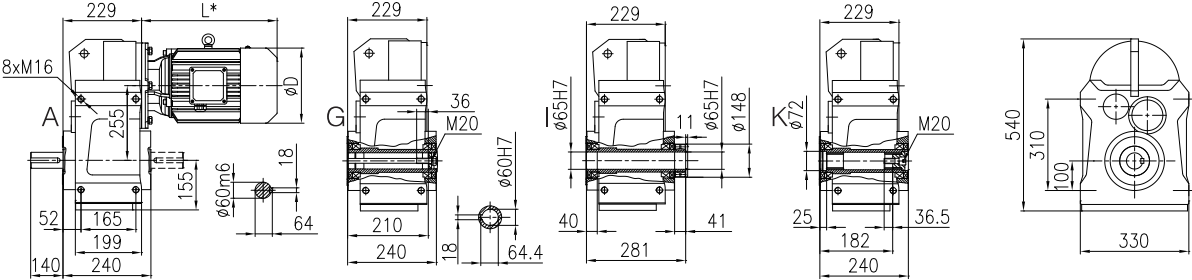
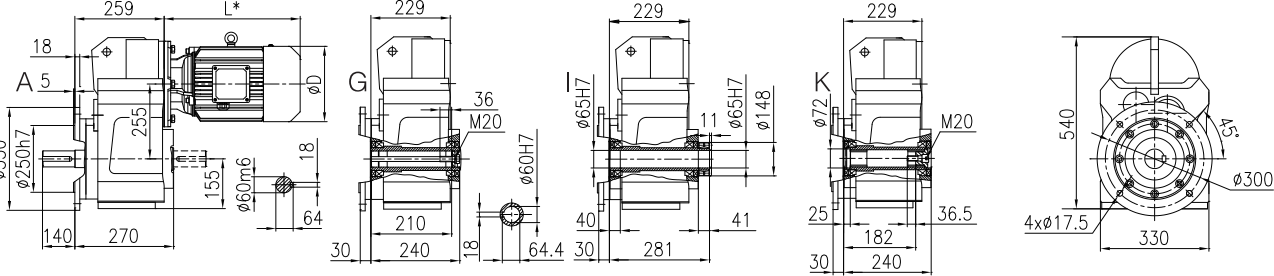
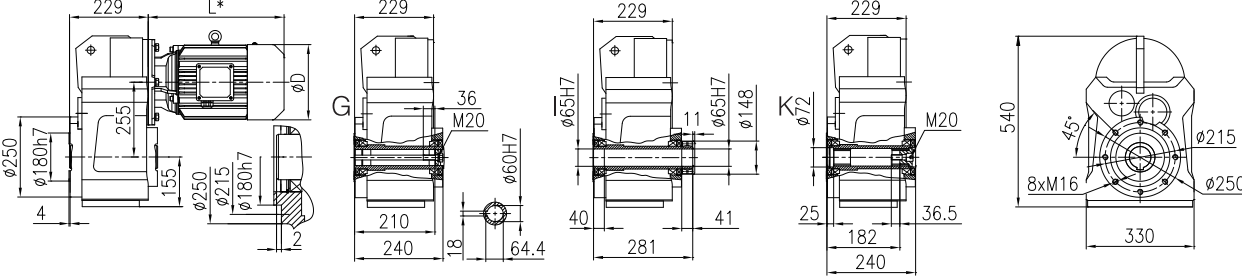
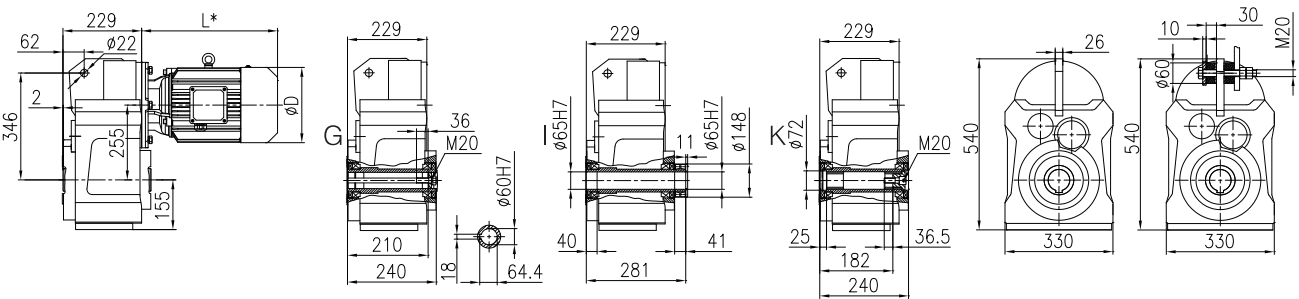
Mounting Mode	F208/F308 Dimensions				
Horizontal foot-mounted	 <p> F208HA Unidirectional output shaft F308HA Unidirectional output shaft F208HC Bidirectional output shaft F308HC Bidirectional output shaft </p> <p> F208HG Hollow shaft with parallel key F308HG Hollow shaft with parallel key </p> <p> F208HI Hollow shaft with shrink disk F308HI Hollow shaft with shrink disk </p> <p> F208HK Hollow shaft with involute spline F308HK Hollow shaft with involute spline </p> <p>Horizontal foot-mounted (H) Weight:92kg (Without motor and oil)</p>				
Flange-mounted	 <p> F208FA Unidirectional output shaft F308FA Unidirectional output shaft F208FC Bidirectional output shaft F308FC Bidirectional output shaft </p> <p> F208FG Hollow shaft with parallel key F308FG Hollow shaft with parallel key </p> <p> F208FI Hollow shaft with shrink disk F308FI Hollow shaft with shrink disk </p> <p> F208FK Hollow shaft with involute spline F308FK Hollow shaft with involute spline </p> <p>Flange-mounted (F) Weight:107kg (Without motor and oil)</p>				
Short flange-mounted	 <p> F208SG Hollow shaft with parallel key F308SG Hollow shaft with parallel key </p> <p> F208SI Hollow shaft with shrink disk F308SI Hollow shaft with shrink disk </p> <p> F208SK Hollow shaft with involute spline F308SK Hollow shaft with involute spline </p> <p>Short flange-mounted (S) Weight:95kg (Without motor and oil)</p>				
Torque arm-mounted	 <p> F208AG Hollow shaft with parallel key F308AG Hollow shaft with parallel key F208TG Hollow shaft with parallel key F308TG Hollow shaft with parallel key </p> <p> F208AI Hollow shaft with shrink disk F208TI Hollow shaft with shrink disk F308TI Hollow shaft with shrink disk </p> <p> F208AK Hollow shaft with involute spline F308AK Hollow shaft with involute spline F208TK Hollow shaft with involute spline F308TK Hollow shaft with involute spline </p> <p>Torque arm-mounted (A) Weight:95kg (Without motor and oil)</p> <p>Torque arm-mounted with accessory (T) Weight:95kg (Without motor and oil)</p>				

Note: Involute spline size DIN 5480: m2 × Z31 × α 30 × D65 × 9H

Corresponding motor dimension table for F208/F308

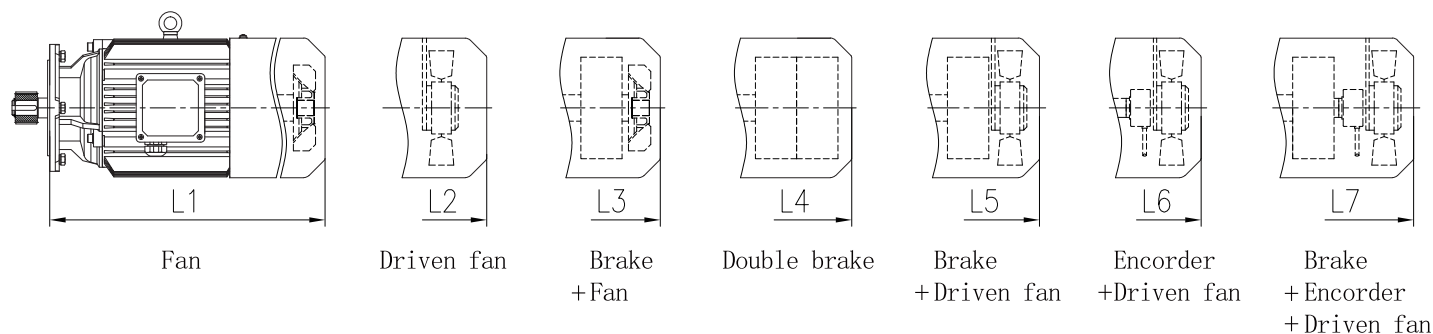

Directly connected motor dimension table

4-pole power (kW)	Range of Ratio	MA						D
		L1	L2	L3	L5	L6	L7	
0.55	224-250	283	328	343	388	388	433	162
0.75	180-250	283	328	343	388	388	433	162
1.1	125-200	331	376	386	436	436	481	176
1.5	90-200	331	376	386	436	436	481	176
2.2	56-200	378	433	453	513	513	558	202
3	45-200	378	433	453	513	513	558	202
4	31.5-160	442	502	517	582	582	622	220
5.5	22.4-100	489	554	569	639	639	669	259
7.5	18-80	489	554	569	639	639	669	259
11	11.2-50	550	600	645	700	700	735	314
15	7.1-40	580	630	675	730	730	765	314
18.5	5-31.5	621	666	731	776	776	816	356
22	4-28	669	714	779	824	824	864	356

Directly connected motor weight table / kg

4-pole power (kW)	Range of Ratio	MA						
		M1	M2	M3	M5	M6	M7	
0.55	224-250	15	16	19	20	16.5	21	
0.75	180-250	16	17	20	21	17.5	22	
1.1	125-200	21	22	25	26	22.5	27	
1.5	90-200	23	24	27	28	24.5	29	
2.2	56-200	36	37	44	45	38	45	
3	45-200	36	37	44	45	38	45	
4	31.5-160	56	57	64	65	58	66	
5.5	22.4-100	77	79	88	90	80	91	
7.5	18-80	88	90	99	101	91	102	
11	11.2-50	129	131	150	151	132	152	
15	7.1-40	161	163	182	183	164	184	
18.5	5-31.5	200	202	232	233	203	235	
22	4-28	220	222	252	253	223	255	

Mounting Mode	F209/F309 Dimensions				
Horizontal foot-mounted					
	<p>F209HA Unidirectional output shaft F309HA Unidirectional output shaft F209HC Bidirectional output shaft F309HC Bidirectional output shaft</p>	<p>F209HG Hollow shaft with parallel key F309HG Hollow shaft with parallel key</p>	<p>F209HI Hollow shaft with shrink disk F309HI Hollow shaft with shrink disk</p>	<p>F209HK Hollow shaft with involute spline F309HK Hollow shaft with involute spline</p>	<p>Horizontal foot-mounted (H) Weight: 160kg (Without motor and oil)</p>
Flange-mounted					
	<p>F209FA Unidirectional output shaft F309FA Unidirectional output shaft F209FC Bidirectional output shaft F309FC Bidirectional output shaft</p>	<p>F209FG Hollow shaft with parallel key F309FG Hollow shaft with parallel key</p>	<p>F209FI Hollow shaft with shrink disk F309FI Hollow shaft with shrink disk</p>	<p>F209FK Hollow shaft with involute spline F309FK Hollow shaft with involute spline</p>	<p>Flange-mounted (F) Weight: 189kg (Without motor and oil)</p>
Short flange-mounted					
	<p>F209SG Hollow shaft with parallel key F309SG Hollow shaft with parallel key</p>	<p>F209SI Hollow shaft with shrink disk F309SI Hollow shaft with shrink disk</p>	<p>F209SK Hollow shaft with involute spline F309SK Hollow shaft with involute spline</p>	<p>Short flange-mounted (S) Weight: 168kg (Without motor and oil)</p>	
Torque arm-mounted					
Torque arm-mounted with accessory	<p>F209AG Hollow shaft with parallel key F309AG Hollow shaft with parallel key F209TG Hollow shaft with parallel key F309TG Hollow shaft with parallel key</p>	<p>F209AI Hollow shaft with shrink disk F309AI Hollow shaft with shrink disk F209TI Hollow shaft with shrink disk F309TI Hollow shaft with shrink disk</p>	<p>F209AK Hollow shaft with involute spline F309AK Hollow shaft with involute spline F209TK Hollow shaft with involute spline F309TK Hollow shaft with involute spline</p>	<p>Torque arm-mounted (A) Weight: 168kg (Without motor and oil)</p> <p>Torque arm-mounted with accessory (T) Weight: 168kg (Without motor and oil)</p>	

Note: Involute spline size DIN 5480: m2 × Z34 × α 30 × D70 × 9H

Corresponding motor dimension table for F209/F309

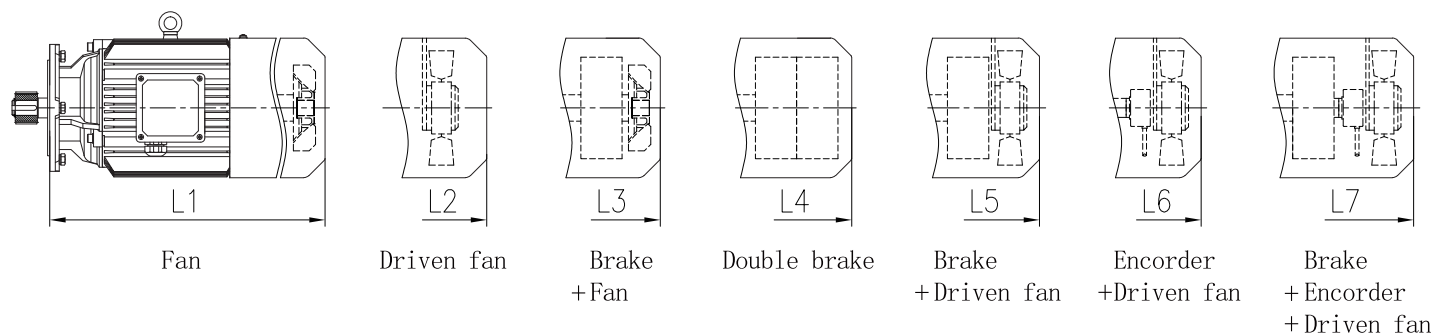

Directly connected motor dimension table

4-pole power (kW)	Range of Ratio	MA						D
		L1	L2	L3	L5	L6	L7	
1.1	180-250	328	373	383	433	433	478	176
1.5	125-250	328	373	383	433	433	478	176
2.2	80-250	374	429	449	509	509	554	202
3	63-250	374	429	449	509	509	554	202
4	45-224	438	498	513	578	578	618	220
5.5	31.5-140	488	553	568	638	638	668	259
7.5	25-112	488	553	568	638	638	668	259
11	16-80	544	594	639	694	694	729	314
15	11.2-56	574	624	669	724	724	759	314
18.5	9-45	615	660	725	770	770	810	356
22	5.6-40	663	708	773	818	818	858	356
30	4-28	705	725	820	845	845	890	398

Directly connected motor weight table / kg

4-pole power (kW)	Range of Ratio	MA						
		M1	M2	M3	M5	M6	M7	
1.1	180-250	21	22	25	26	22.5	27	
1.5	125-250	23	24	27	28	24.5	29	
2.2	80-250	36	37	44	45	38	45	
3	63-250	36	37	44	45	38	45	
4	45-224	56	57	64	65	58	66	
5.5	31.5-140	77	79	88	90	80	91	
7.5	25-112	88	90	99	101	91	102	
11	16-80	129	131	150	151	132	152	
15	11.2-56	161	163	182	183	164	184	
18.5	9-45	200	202	232	233	203	235	
22	5.6-40	220	222	252	253	223	255	
30	4-28	280	280	330	328	281	330	

Mounting Mode	F210/F310 Dimensions				
Horizontal foot-mounted	<p> F210HA Unidirectional output shaft F310HA Unidirectional output shaft F210HC Bidirectional output shaft F310HC Bidirectional output shaft </p> <p> F210HG Hollow shaft with parallel key F310HG Hollow shaft with parallel key </p> <p> F210HI Hollow shaft with shrink disk F310HI Hollow shaft with shrink disk </p> <p> F210HK Hollow shaft with involute spline F310HK Hollow shaft with involute spline </p> <p>Horizontal foot-mounted (H) Weight:240kg (Without motor and oil)</p>				
Flange-mounted	<p> F210FA Unidirectional output shaft F310FA Unidirectional output shaft F210FC Bidirectional output shaft F310FC Bidirectional output shaft </p> <p> F210FG Hollow shaft with parallel key F310FG Hollow shaft with parallel key </p> <p> F210FI Hollow shaft with shrink disk F310FI Hollow shaft with shrink disk </p> <p> F210FK Hollow shaft with involute spline F310FK Hollow shaft with involute spline </p> <p>Flange-mounted (F) Weight:270kg (Without motor and oil)</p>				
Short flange-mounted	<p> F210SG Hollow shaft with parallel key F310SG Hollow shaft with parallel key </p> <p> F210SI Hollow shaft with shrink disk F310SI Hollow shaft with shrink disk </p> <p> F210SK Hollow shaft with involute spline F310SK Hollow shaft with involute spline </p> <p>Short flange-mounted (S) Weight:250kg (Without motor and oil)</p>				
Torque arm-mounted	<p> F210AG Hollow shaft with parallel key F310AG Hollow shaft with parallel key F210TG Hollow shaft with parallel key F310TG Hollow shaft with parallel key </p> <p> F210AI Hollow shaft with shrink disk F310AI Hollow shaft with shrink disk F210TI Hollow shaft with shrink disk F310TI Hollow shaft with shrink disk </p> <p> F210AK Hollow shaft with involute spline F310AK Hollow shaft with involute spline F210TK Hollow shaft with involute spline F310TK Hollow shaft with involute spline </p> <p>Torque arm-mounted (A) Weight:252kg (Without motor and oil)</p> <p>Torque arm-mounted with accessory (T) Weight:252kg (Without motor and oil)</p>				

Note: Involute spline size DIN 5480: m3 × Z27 × α30 × D85 × 9H

Corresponding motor dimension table for F210/F310

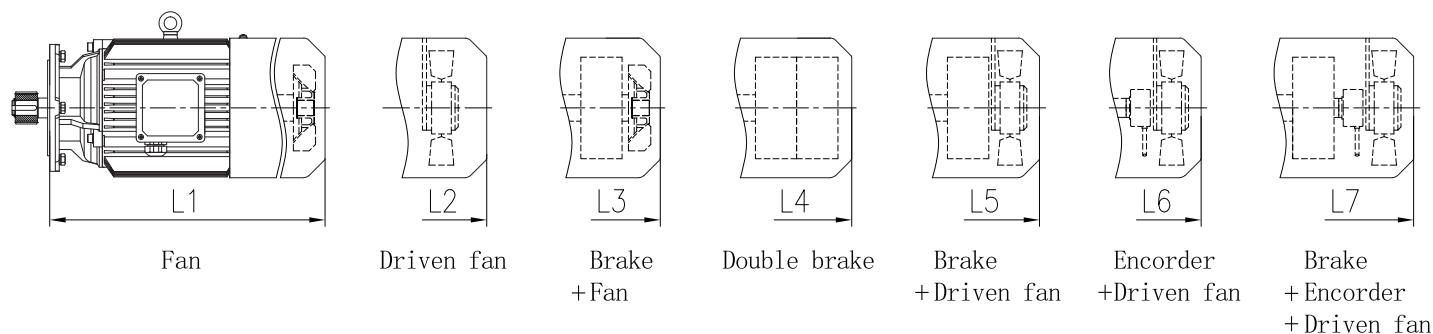

Directly connected motor dimension table

4-pole power (kW)	Range of Ratio	MA						D
		L1	L2	L3	L5	L6	L7	
2.2	160-224	370	425	445	505	505	550	202
3	112-224	370	425	445	505	505	550	202
4	90-224	434	494	509	574	574	614	220
5.5	63-140	477	542	557	627	627	657	259
7.5	40-140	477	542	557	627	627	657	259
11	28-140	533	583	628	683	683	718	314
15	16-100	563	613	658	713	713	748	314
18.5	10-80	604	649	714	759	759	799	356
22	9-71	652	697	762	807	807	847	356
30	5.6-50	705	725	820	845	845	890	398
37	5-40	746	781	861	901	901	941	446
45	5-31.5	746	781	861	901	901	941	446

Directly connected motor weight table / kg

4-pole power (kW)	Range of Ratio	MA						
		M1	M2	M3	M5	M6	M7	
2.2	160-224	36	37	44	45	38	45	
3	112-224	36	37	44	45	38	45	
4	90-224	56	57	64	65	58	66	
5.5	63-140	77	79	88	90	80	91	
7.5	40-140	88	90	99	101	91	102	
11	28-140	129	131	150	151	132	152	
15	16-100	161	163	182	183	164	184	
18.5	10-80	200	202	232	233	203	235	
22	9-71	220	222	252	253	223	255	
30	5.6-50	280	280	330	328	281	330	
37	5-40	345	347	395	396	349	398	
45	5-31.5	365	367	415	416	369	418	

Mounting Mode	F212/F312 Dimensions				
Horizontal foot-mounted	<p> F212HA Unidirectional output shaft F312HA Unidirectional output shaft F212HC Bidirectional output shaft F312HC Bidirectional output shaft </p> <p> F212HG Hollow shaft with parallel key F312HG Hollow shaft with parallel key </p> <p> F212HI Hollow shaft with shrink disk F312HI Hollow shaft with shrink disk </p> <p> F212HK Hollow shaft with involute spline F312HK Hollow shaft with involute spline </p> <p>Horizontal foot-mounted (H) Weight:400kg (Without motor and oil)</p>				
Flange-mounted	<p> F212FA Unidirectional output shaft F312FA Unidirectional output shaft F212FC Bidirectional output shaft F312FC Bidirectional output shaft </p> <p> F212FG Hollow shaft with parallel key F312FG Hollow shaft with parallel key </p> <p> F212FI Hollow shaft with shrink disk F312FI Hollow shaft with shrink disk </p> <p> F212FK Hollow shaft with involute spline F312FK Hollow shaft with involute spline </p> <p>Flange-mounted (F) Weight:454kg (Without motor and oil)</p>				
Short flange-mounted	<p> F212SG Hollow shaft with parallel key F312SG Hollow shaft with parallel key </p> <p> F212SI Hollow shaft with shrink disk F312SI Hollow shaft with shrink disk </p> <p> F212SK Hollow shaft with involute spline F312SK Hollow shaft with involute spline </p> <p>Short flange-mounted (S) Weight:420kg (Without motor and oil)</p>				
Torque arm-mounted	<p> F212AG Hollow shaft with parallel key F312AG Hollow shaft with parallel key F212TG Hollow shaft with parallel key F312TG Hollow shaft with parallel key </p> <p> F212AI Hollow shaft with shrink disk F312AI Hollow shaft with shrink disk F212TI Hollow shaft with shrink disk F312TI Hollow shaft with shrink disk </p> <p> F212AK Hollow shaft with involute spline F312AK Hollow shaft with involute spline F212TK Hollow shaft with involute spline F312TK Hollow shaft with involute spline </p> <p>Torque arm-mounted (A) Weight:420kg (Without motor and oil)</p> <p>Torque arm-mounted with accessory (T) Weight:420kg (Without motor and oil)</p>				

Note: Involute spline size DIN 5480: m3 × Z30 × α30 × D95 × H9

Corresponding motor dimension table for F212/F312

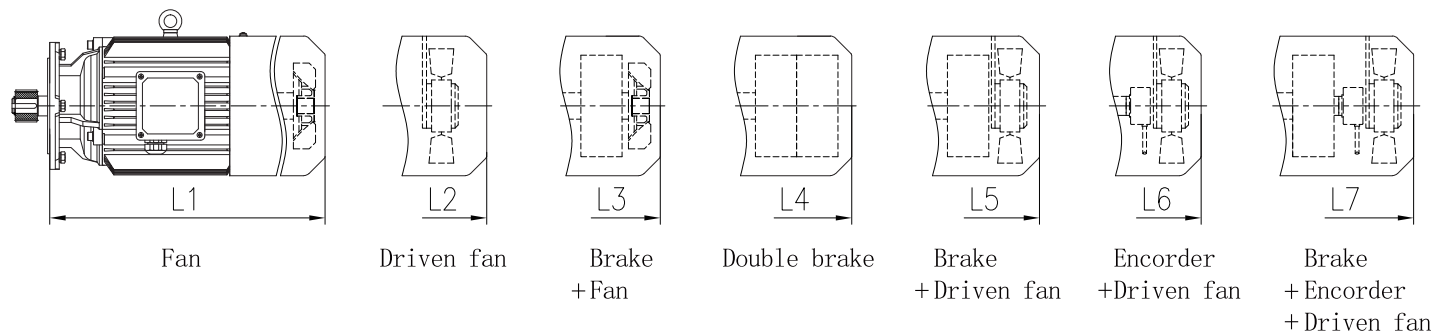

Directly connected motor dimension table

4-pole power (kW)	Range of Ratio	MA						D
		L1	L2	L3	L5	L6	L7	
2.2	200-224	359	414	434	494	494	539	202
3	160-224	359	414	434	494	494	539	202
4	125-224	423	483	498	563	563	603	220
5.5	90-180	467	532	547	617	617	647	259
7.5	63-180	467	532	547	617	617	647	259
11	45-180	517	567	612	667	667	702	314
15	31.5-140	547	597	642	697	697	732	314
18.5	25-125	588	633	698	743	743	783	356
22	22.4-100	636	681	746	791	791	831	356
30	14-71	684	704	799	824	824	869	398
37	11.2-56	725	760	840	880	880	920	446
45	7.1-50	725	760	840	880	880	920	446
55	5-40	841	866	981	1021	1021	1041	485
75	5-28	886	916	1026	1066	1066	1106	547
90	5-25	937	967	1077	1117	1117	1157	547

Directly connected motor weight table / kg

4-pole power (kW)	Range of Ratio	MA						
		M1	M2	M3	M5	M6	M7	
2.2	200-224	36	37	44	45	38	45	
3	160-224	36	37	44	45	38	45	
4	125-224	56	57	64	65	58	66	
5.5	90-180	77	79	88	90	80	91	
7.5	63-180	88	90	99	101	91	102	
11	45-180	129	131	150	151	132	152	
15	31.5-140	161	163	182	183	164	184	
18.5	25-125	200	202	232	233	203	235	
22	22.4-100	220	222	252	253	223	255	
30	14-71	280	280	330	328	281	330	
37	11.2-56	345	347	395	396	349	398	
45	7.1-50	365	367	415	416	369	418	
55	5-40	470	471	575	570	470	572	
75	5-28	630	632	735	733	633	735	
90	5-25	710	712	815	813	713	815	

Mounting Mode	F215/F315 Dimensions				
Horizontal foot-mounted					
	<p>F215HA Unidirectional output shaft F315HA Unidirectional output shaft F215HC Bidirectional output shaft F315HC Bidirectional output shaft</p>	<p>F215HG Hollow shaft with parallel key F315HG Hollow shaft with parallel key</p>	<p>F215HI Hollow shaft with shrink disk F315HI Hollow shaft with shrink disk</p>	<p>F215HK Hollow shaft with involute spline F315HK Hollow shaft with involute spline</p>	<p>Horizontal foot-mounted (H) Weight:680kg (Without motor and oil)</p>
Flange-mounted					
	<p>F215FA Unidirectional output shaft F315FA Unidirectional output shaft F215FC Bidirectional output shaft F315FC Bidirectional output shaft</p>	<p>F215FG Hollow shaft with parallel key F315FG Hollow shaft with parallel key</p>	<p>F215FI Hollow shaft with shrink disk F315FI Hollow shaft with shrink disk</p>	<p>F215FK Hollow shaft with involute spline F315FK Hollow shaft with involute spline</p>	<p>Flange-mounted (F) Weight:780kg (Without motor and oil)</p>
Short flange-mounted					
		<p>F215SG Hollow shaft with parallel key F315SG Hollow shaft with parallel key</p>	<p>F215SI Hollow shaft with shrink disk F315SI Hollow shaft with shrink disk</p>	<p>F215SK Hollow shaft with involute spline F315SK Hollow shaft with involute spline</p>	<p>Short flange-mounted (S) Weight:715kg (Without motor and oil)</p>
Torque arm-mounted					
Torque arm-mounted with accessory		<p>F215AG Hollow shaft with parallel key F315AG Hollow shaft with parallel key F215TG Hollow shaft with parallel key F315TG Hollow shaft with parallel key</p>	<p>F215AI Hollow shaft with shrink disk F315AI Hollow shaft with shrink disk F215TI Hollow shaft with shrink disk F315TI Hollow shaft with shrink disk</p>	<p>F215AK Hollow shaft with involute spline F315AK Hollow shaft with involute spline F215TK Hollow shaft with involute spline F315TK Hollow shaft with involute spline</p>	<p>Torque arm-mounted (A) Torque arm-mounted with accessory (T) Weight:715kg Weight:715kg (Without motor and oil) (Without motor and oil)</p>

Note:Involute spline size DIN 5480: m3 × Z38 × α30 × D120 × 9H

Corresponding motor dimension table for F215/F315

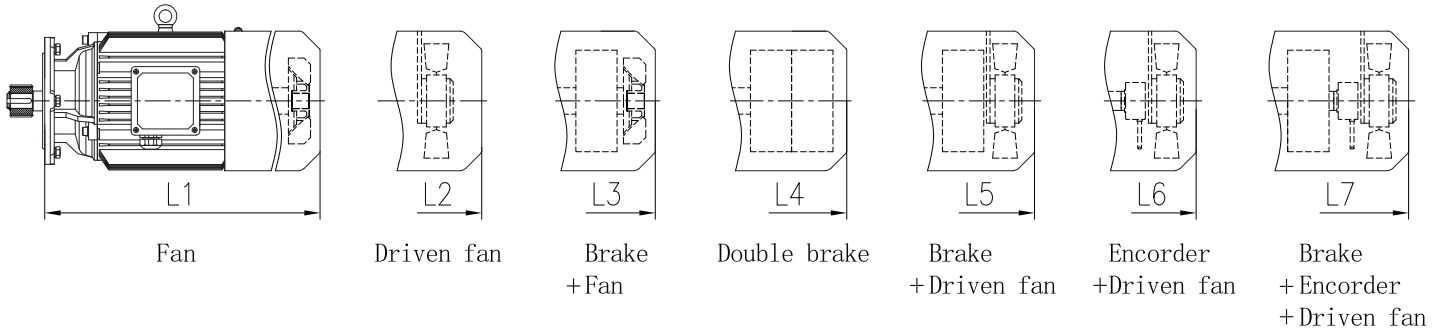

Directly connected motor dimension table

4-pole power (kW)	Range of Ratio	MA						D
		L1	L2	L3	L5	L6	L7	
7.5	112-180	467	532	547	617	617	647	259
11	71-180	502	552	597	652	652	687	314
15	56-180	532	582	627	682	682	717	314
18.5	45-180	573	618	683	728	728	768	356
22	35.5-180	621	666	731	776	776	816	356
30	28-125	674	694	789	814	814	859	398
37	20-100	715	750	830	870	870	910	446
45	16-80	715	750	830	870	870	910	446
55	12.5-71	831	856	971	1011	1011	1031	485
75	8-50	876	906	1016	1056	1056	1096	547
90	7.1-40	927	957	1067	1107	1107	1147	547

Directly connected motor weight table / kg

4-pole power (kW)	Range of Ratio	MA						
		M1	M2	M3	M5	M6	M7	
7.5	112-180	88	90	99	101	91	102	
11	71-180	129	131	150	151	132	152	
15	56-180	161	163	182	183	164	184	
18.5	45-180	200	202	232	233	203	235	
22	35.5-180	220	222	252	253	223	255	
30	28-125	280	280	330	328	281	330	
37	20-100	345	347	395	396	349	398	
45	16-80	365	367	415	416	369	418	
55	12.5-71	470	471	575	570	470	572	
75	8-50	630	632	735	733	633	735	
90	7.1-40	710	712	815	813	713	815	

7 Input Flange and Input Shaft

7.1 F series dimensions of AP input flange

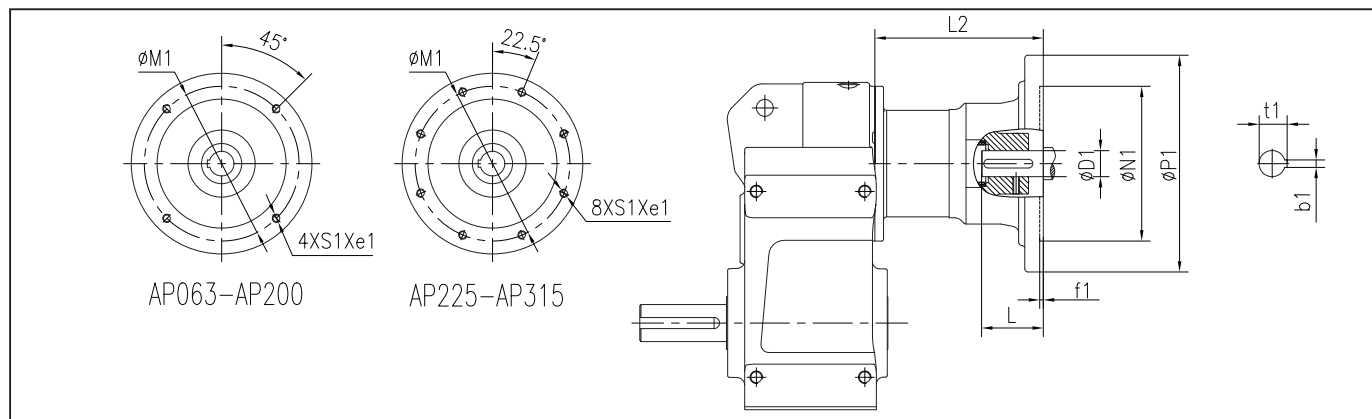

Size	Flange	Range of Ratio	e1	D1	N1	M1	P1	f1	b1	t1	L	S1	L2	Weight (kg)
F202 F302	AP063	4-112	14	11H7	95H7	115	140	4	4	12.8	23	M8	59	4.8
	AP071	4-112	14	14H7	110H7	130	160	4	5	16.3	30	M8	59	4.8
	AP080	4-50	18	19H7	130H7	165	200	4	6	21.8	40	M10	74	7.6
F203 F303	AP063	4-125	14	11H7	95H7	115	140	4	4	12.8	23	M8	59	4.8
	AP071	4-125	14	14H7	110H7	130	160	4	5	16.3	30	M8	59	4.8
	AP080	4-80	18	19H7	130H7	165	200	4	6	21.8	40	M10	74	7.6
F204 F304	AP063	4.5-160	14	11H7	95H7	115	140	4	4	12.8	23	M8	61	5.1
	AP071	4.5-160	14	14H7	110H7	130	160	4	5	16.3	30	M8	61	5.1
	AP080	4.5-140	18	19H7	130H7	165	200	4	6	21.8	40	M10	76	8.6
	AP090	4.5-71	18	24H7	130H7	165	200	4	8	27.3	50	M10	81	9.2
	AP100	4.5-40	28	28H7	180H7	215	250	5	8	31.3	60	M12	191	14.1
	AP112	4.5-20	28	28H7	180H7	215	250	5	8	31.3	60	M12	191	14.1
F205 F305	AP063	4-140	14	11H7	95H7	115	140	4	4	12.8	23	M8	61	5.1
	AP071	4-140	14	14H7	110H7	130	160	4	5	16.3	30	M8	61	5.1
	AP080	4-140	18	19H7	130H7	165	200	4	6	21.8	40	M10	76	8.6
	AP090	4-80	18	24H7	130H7	165	200	4	8	27.3	50	M10	81	9.2
	AP100	4-56	28	28H7	180H7	215	250	5	8	31.3	60	M12	191	14.1
	AP112	4-31.5	28	28H7	180H7	215	250	5	8	31.3	60	M12	191	14.1
F206 F306	AP063	4-200	14	11H7	95H7	115	140	4	4	12.8	23	M8	61	5.1
	AP071	4-200	14	14H7	110H7	130	160	4	5	16.3	30	M8	61	5.1
	AP080	4-200	18	19H7	130H7	165	200	4	6	21.8	40	M10	76	8.6
	AP090	4-112	18	24H7	130H7	165	200	4	8	27.3	50	M10	81	9.2
	AP100	4-80	28	28H7	180H7	215	250	5	8	31.3	60	M12	191	14.1
	AP112	4-40	28	28H7	180H7	215	250	5	8	31.3	60	M12	191	14.1
F207 F307	AP071	20-250	14	14H7	110H7	130	160	4	5	16.3	30	M8	53	6.7
	AP080	20-250	18	19H7	130H7	165	200	4	6	21.8	40	M10	68	10.3
	AP090	4-160	18	24H7	130H7	165	200	4	8	27.3	50	M10	73	11.1
	AP100	4-140	28	28H7	180H7	215	250	5	8	31.3	60	M12	181	15.5
	AP112	4-80	28	28H7	180H7	215	250	5	8	31.3	60	M12	181	15.5
	AP132	4-56	28	38H7	230H7	265	300	5	10	41.3	80	M12	210	22.3

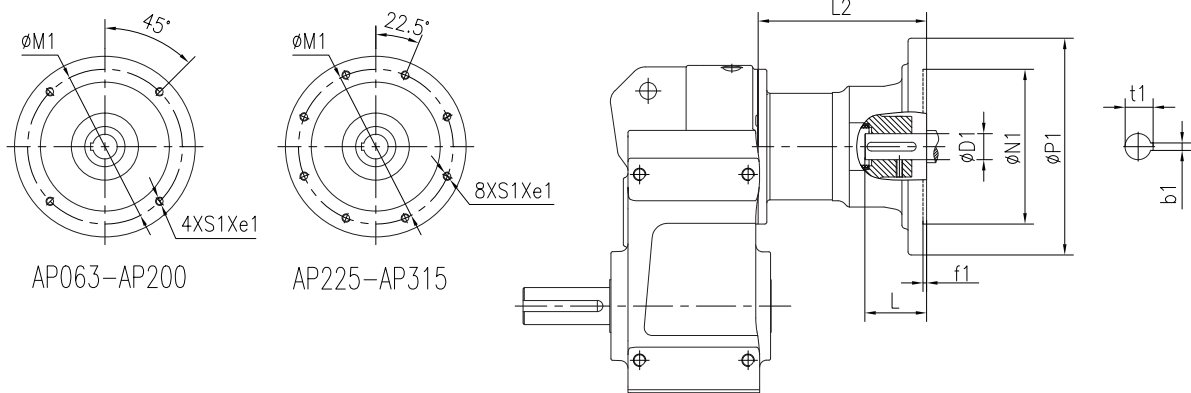

Size	Flange	Range of Ratio	e1	D1	N1	M1	P1	f1	b1	t1	L	S1	L2	Weight (kg)
F208 F308	AP080	112-250	18	19H7	130H7	165	200	4	6	21.8	40	M10	65	10.4
	AP090	4-200	18	24H7	130H7	165	200	4	8	27.3	50	M10	66	12.1
	AP100	4-200	28	28H7	180H7	215	250	5	8	31.3	60	M12	171	18.2
	AP112	4-160	28	28H7	180H7	215	250	5	8	31.3	60	M12	171	18.2
	AP132	4-100	28	38H7	230H7	265	300	5	10	41.3	80	M12	203	24.9
	AP160	4-50	40	42H7	250H7	300	350	6	12	45.3	110	M16	272	46.4
	AP180	4-31.5	40	48H7	250H7	300	350	6	14	51.8	110	M16	272	46.4
F209 F309	AP090	4-250	18	24H7	130H7	165	200	4	8	27.3	50	M10	61	14.7
	AP100	4-250	28	28H7	180H7	215	250	5	8	31.3	60	M12	172	21.5
	AP112	4-224	28	28H7	180H7	215	250	5	8	31.3	60	M12	172	21.5
	AP132	4-140	28	38H7	230H7	265	300	5	10	41.3	80	M12	202	28.3
	AP160	4-80	40	42H7	250H7	300	350	6	12	45.3	110	M16	270	49.9
	AP180	4-45	40	48H7	250H7	300	350	6	14	51.8	110	M16	270	49.9
	AP200	4-28	40	55H7	300H7	350	400	6	16	59.3	110	M16	327	72.8
F210 F310	AP100	16-224	28	28H7	180H7	215	250	5	8	31.3	60	M12	162	25.6
	AP112	16-224	28	28H7	180H7	215	250	5	8	31.3	60	M12	162	25.6
	AP132	5-140	28	38H7	230H7	265	300	5	10	41.3	80	M12	189	33.7
	AP160	5-140	40	42H7	250H7	300	350	6	12	45.3	110	M16	257	52.3
	AP180	5-80	40	48H7	250H7	300	350	6	14	51.8	110	M16	257	52.3
	AP200	5-50	40	55H7	300H7	350	400	6	16	59.3	110	M16	327	77.4
	AP225	5-40	30	60H7	350H7	400	450	6	18	64.4	140	M16	354	85.1
F212 F312	AP132	5-180	28	38H7	230H7	265	300	5	10	41.3	80	M12	175	46.4
	AP160	5-180	40	42H7	250H7	300	350	6	12	45.3	110	M16	243	66.9
	AP180	5-125	40	48H7	250H7	300	350	6	14	51.8	110	M16	243	66.9
	AP200	5-71	40	55H7	300H7	350	400	6	16	59.3	110	M16	316	89.8
	AP225	5-56	30	60H7	350H7	400	450	6	18	64.4	140	M16	343	97.5
	AP250	5-40	32	65H7	450H7	500	550	7	18	69.4	140	M16	361	131.3
	AP280	5-28	32	75H7	450H7	500	550	7	20	79.9	140	M16	361	131.3
F215 F315	AP160	14-180	40	42H7	250H7	300	350	6	12	45.3	110	M16	233	90.9
	AP180	14-180	40	48H7	250H7	300	350	6	14	51.8	110	M16	233	90.9
	AP200	6.3-125	40	55H7	300H7	350	400	6	16	59.3	110	M16	298	109.4
	AP225	6.3-100	30	60H7	350H7	400	450	6	18	64.4	140	M16	325	117.1
	AP250	6.3-71	32	65H7	450H7	500	550	7	18	69.4	140	M16	343	147.8
	AP280	6.3-50	32	75H7	450H7	500	550	7	20	79.9	140	M16	343	147.8
	AP315	6.3-35.5	35	80H7	550H7	600	660	7	22	85.4	170	M20	447	262.5

7.2 F series dimensions of AN input flange

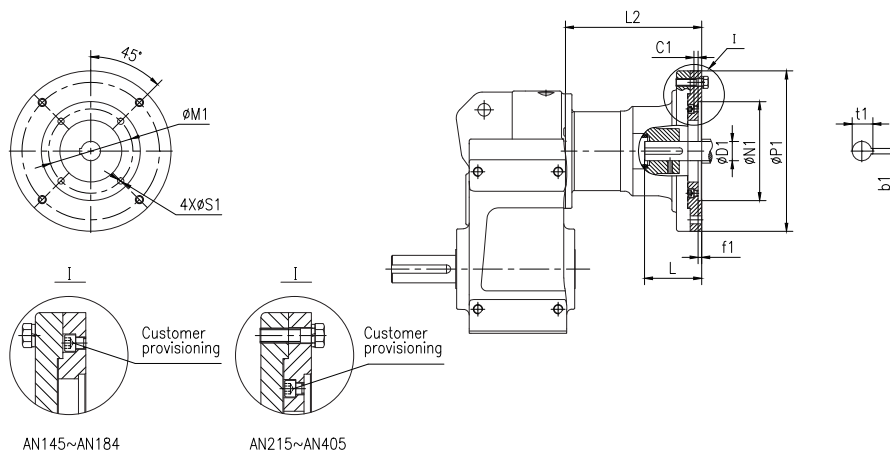

Size	Flange	NEMA Motor Frame	Power (HP)	IEC Standard Power (KW)	c1	D1	N1	M1	P1	f1	b1	t1	L	S1	L2
F202 F302	AN145	143TC	1/1.5	0.75/1.1	6	22.225H7	114.3H7	149.2	200	5	4.76	24.7	58.04	11	92
		145TC	2	1.5											
F203 F303	AN145	143TC	1/1.5	0.75/1.1	6	22.225H7	114.3H7	149.2	200	5	4.76	24.7	58.04	11	92
		145TC	2	1.5											
F204 F304	AN145	143TC	1/1.5	0.75/1.1	6	22.225H7	114.3H7	149.2	200	5	4.76	24.7	58.04	11	94
		145TC	2	1.5											
	AN184	182TC	3	2.2	8	28.575H7	215.9H7	184.2	250	8	6.35	31.7	73.03	13.5	220.5
		184TC	5	4											
F205 F305	AN145	143TC	1/1.5	0.75/1.1	6	22.225H7	114.3H7	149.2	200	5	4.76	24.7	58.04	11	94
		145TC	2	1.5											
	AN184	182TC	3	2.2	8	28.575H7	215.9H7	184.2	250	8	6.35	31.7	73.03	13.5	220.5
		184TC	5	4											
F206 F306	AN145	143TC	1/1.5	0.75/1.1	6	22.225H7	114.3H7	149.2	200	5	4.76	24.7	58.04	11	94
		145TC	2	1.5											
	AN184	182TC	3	2.2	8	28.575H7	215.9H7	184.2	250	8	6.35	31.7	73.03	13.5	220.5
		184TC	5	4											
	AN215	213TC	7.5	5.5	9	34.925H7	215.9H7	184.15	300	8	7.94	38.7	85.73	13.5	245
215TC		10	7.5												
F207 F307	AN145	143TC	1/1.5	0.75/1.1	6	22.225H7	114.3H7	149.2	200	5	4.76	24.7	58.04	11	86
		145TC	2	1.5											
	AN184	182TC	3	2.2	8	28.575H7	215.9H7	184.2	250	8	6.35	31.7	73.03	13.5	210.5
		184TC	5	4											
	AN215	213TC	7.5	5.5	9	34.925H7	215.9H7	184.15	300	8	7.94	38.7	85.73	13.5	235
215TC		10	7.5												
F208 F308	AN145	143TC	1/1.5	0.75/1.1	6	22.225H7	114.3H7	149.2	200	5	4.76	24.7	58.04	11	83
		145TC	2	1.5											
	AN184	182TC	3	2.2	8	28.575H7	215.9H7	184.2	250	8	6.35	31.7	73.03	13.5	200.5
		184TC	5	4											
	AN215	213TC	7.5	5.5	9	34.925H7	215.9H7	184.15	300	8	7.94	38.7	85.73	13.5	228
		215TC	10	7.5											
AN256	254TC	15	11	9	41.275H7	215.9H7	184.15	350	8	9.53	45.8	101.6	13.5	297	
	256TC	20	15												
F209 F309	AN184	182TC	3	2.2	8	28.575H7	215.9H7	184.2	250	8	6.35	31.7	73.03	13.5	201.5
		184TC	5	4											
	AN215	213TC	7.5	5.5	9	34.925H7	215.9H7	184.15	300	8	7.94	38.7	85.73	13.5	227
		215TC	10	7.5											
	AN256	254TC	15	11	9	41.275H7	215.9H7	184.15	350	8	9.53	45.8	101.6	13.5	296
		256TC	20	15											
	AN286	284TC	25	18.5	9	47.625H7	266.7H7	228.6	400	8	12.7	53.4	117.48	13.5	352
		286TC	30	22											

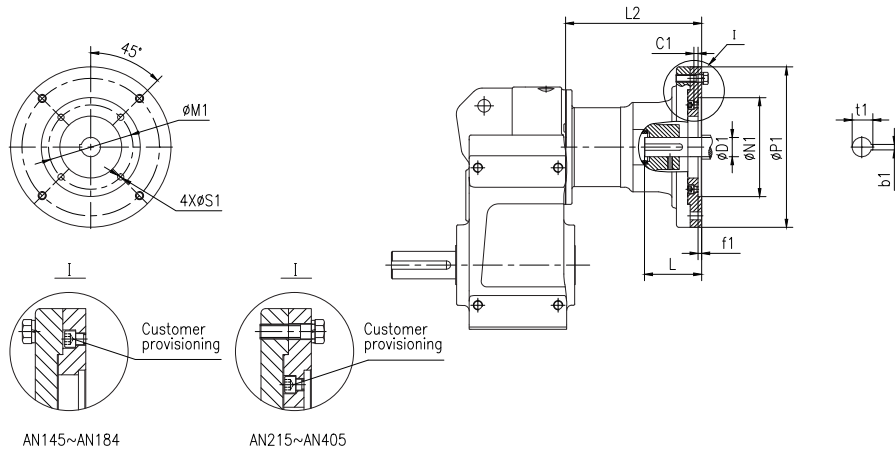

Size	Flange	NEMA Motor Frame	Power (HP)	IEC Standard Power (KW)	c1	D1	N1	M1	P1	f1	b1	t1	L	S1	L2
F210 F310	AN184	182TC	3	2.2	8	28.575H7	215.9H7	184.2	250	8	6.35	31.7	73.03	13.5	191.5
		184TC	5	4											
	AN215	213TC	7.5	5.5	9	34.925H7	215.9H7	184.15	300	8	7.94	38.7	85.73	13.5	214
		215TC	10	7.5											
	AN256	254TC	15	11	9	41.275H7	215.9H7	184.15	350	8	9.53	45.8	101.6	13.5	283
		256TC	20	15											
	AN286	284TC	25	18.5	9	47.625H7	266.7H7	228.6	400	8	12.7	53.4	117.48	13.5	252
		286TC	30	22											
	AN326	324TC	40	30	9.5	53.975H7	317.5H7	279.4	450	8	12.7	60	133.35	17.5	384
		326TC	50	37											
AN365	364TC	60	45	24.5	60.325H7	317.5H7	279.4	450	8	15.88	67.6	149.23	17.5	399	
	365TC	75	55												
F212 F312	AN215	213TC	7.5	5.5	9	34.925H7	215.9H7	184.15	300	8	7.94	38.7	85.73	13.5	200
		215TC	10	7.5											
	AN256	254TC	15	11	9	41.275H7	215.9H7	184.15	350	8	9.53	45.8	101.6	13.5	269
		256TC	20	15											
	AN286	284TC	25	18.5	9	47.625H7	266.7H7	228.6	400	8	12.7	53.4	117.48	13.5	341
		286TC	30	22											
	AN326	324TC	40	30	9.5	53.975H7	317.5H7	279.4	450	8	12.7	60	133.35	17.5	373
		326TC	50	37											
	AN365	364TC	60	45	24.5	60.325H7	317.5H7	279.4	450	8	15.88	67.6	149.23	17.5	388
		365TC	75	55											
AN405	405TC	100	75	64.5	73.025H7	317.5H7	279.4	450	8	19.05	81.9	184.15	17.5	433	
F215 F315	AN256	254TC	15	11	9	41.275H7	215.9H7	184.15	350	8	9.53	45.8	101.6	13.5	259
		256TC	20	15											
	AN286	284TC	25	18.5	9	47.625H7	266.7H7	228.6	400	8	12.7	53.4	117.48	13.5	323
		286TC	30	22											
	AN326	324TC	40	30	9.5	53.975H7	317.5H7	279.4	450	8	12.7	60	133.35	17.5	355
		326TC	50	37											
	AN365	364TC	60	45	24.5	60.325H7	317.5H7	279.4	450	8	15.88	67.6	149.23	17.5	370
		365TC	75	55											
AN405	405TC	100	75	64.5	73.025H7	317.5H7	279.4	450	8	19.05	81.9	184.15	17.5	415	

7.3 F series dimensions of AE input shaft

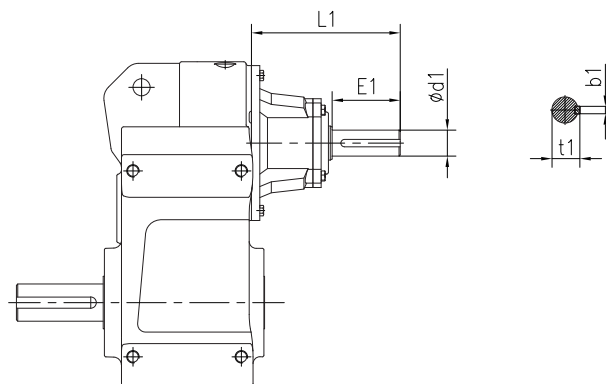

Size	Input Shaft	Range of Power	Range of Ratio	d1	E1	L1	b1	t1	Weight (kg)
F202 F302	AE200	0.12-0.75kW	4-112	19k6	40	117	6	21.5	2.5
F203 F303	AE200	0.12-0.75kW	4-125	19k6	40	117	6	21.5	2.5
F204 F304	AE200	0.12-0.75kW	4.5-160	19k6	40	119	6	21.5	3.4
	AE300	1.1-4kW	4.5-50	28k6	60	175	8	31	6.1
F205 F305	AE200	0.12-0.75kW	4-140	19k6	40	119	6	21.5	3.4
	AE300	1.1-4kW	4-80	28k6	60	175	8	31	6.1
F206 F306	AE200	0.12-0.75kW	4-200	19k6	40	119	6	21.5	3.4
	AE300	1.1-4kW	4-112	28k6	60	175	8	31	6.1
F207 F307	AE200	0.12-0.75kW	20-250	19k6	40	111	6	21.5	4.9
	AE300	1.1-4kW	4-160	28k6	60	165	8	31	7.5
	AE400	5.5-7.5kW	4-40	38k6	80	211	10	41	10.5
F208 F308	AE200	0.12-0.75kW	112-250	19k6	40	108	6	21.5	7.2
	AE300	1.1-4kW	4-200	28k6	60	155	8	31	10.2
	AE400	5.5-11kW	4-80	38k6	80	204	10	41	13.1
	AE500	15-22kW	4-40	42k6	110	266	12	45	23.3

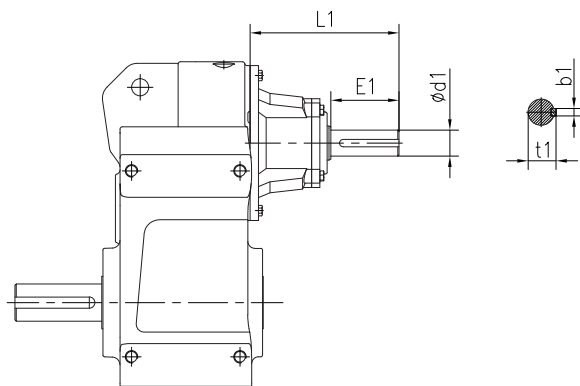

Size	Input Shaft	Range of Power	Range of Ratio	d1	E1	L1	b1	t1	Weight (kg)
F209 F309	AE300	1.1-4kW	4-250	28k6	60	156	8	31	10.2
	AE400	5.5-11kW	4-112	38k6	80	203	10	41	13.1
	AE500	15-22kW	4-56	42k6	110	265	12	45	23.3
	AE600	30-45KW	4-28	48k6	110	309	14	51.5	40.9
F210 F310	AE300	1.1-4kW	16-224	28k6	60	146	8	31	17.6
	AE400	5.5-11kW	5-140	38k6	80	190	10	41	21.9
	AE500	15-22kW	5-100	42k6	110	252	12	45	29.2
	AE600	30-45KW	5-50	48k6	110	309	14	51.5	45.5
F212 F312	AE400	5.5-11kW	5-180	38k6	80	176	10	41	34.6
	AE500	15-22kW	5-140	42k6	110	238	12	45	43.8
	AE600	30-45KW	5-71	48k6	110	298	14	51.5	57.9
	AE700	55-90KW	5-40	55m6	110	297	16	59	64.6
	AE800	110-200KW	5-20	70m6	140	377	20	74.5	87.8
F215 F315	AE500	15-22KW	14-180	42k6	110	228	12	45	67.8
	AE600	30-45KW	6.3-125	48k6	110	280	14	51.5	77.5
	AE700	55-90KW	6.3-71	55m6	110	279	16	59	81.1
	AE800	110-200KW	6.3-35.5	70m6	140	361	20	74.5	104.8

8 Combi-type Dimensions

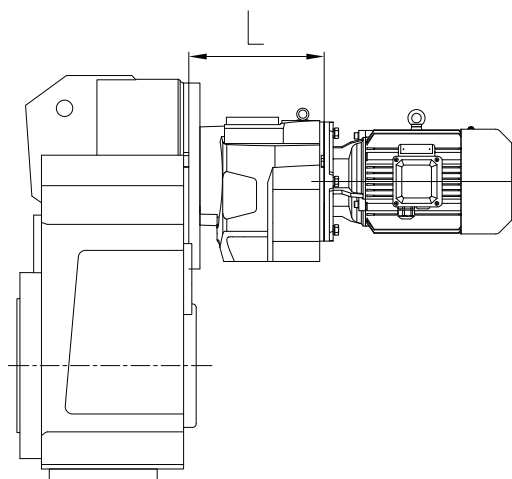

Type	F302/C201 F302/C301	F203/C201 F303/C201 F303/C301	F204/C203 F304/C203 F304/C303	F205/C203 F305/C203 F305/C303	F306/C203 F306/C303	F207/C203 F307/C203 F307/C303
L	134	134	170	170	170	162
Range of Motor Power (kW)	0.12-0.25	0.12-0.37	0.12-0.55	0.12-0.75	0.12-1.1	0.12-1.5
Type	F208/C205 F308/C205 F308/C305	F209/C205 F309/C205 F309/C305	F210/C207 F310/C207 F310/C307	F312/C207 F312/C307	F212/C208	F215/C209 F315/C209 F315/C309
L	182	183	226	226	258	321
Range of Motor Power (kW)	0.12-4	0.12-4	0.12-7.5	0.12-11	0.55-11	0.55-22

9 Motor Rainproof Cover Dimensions

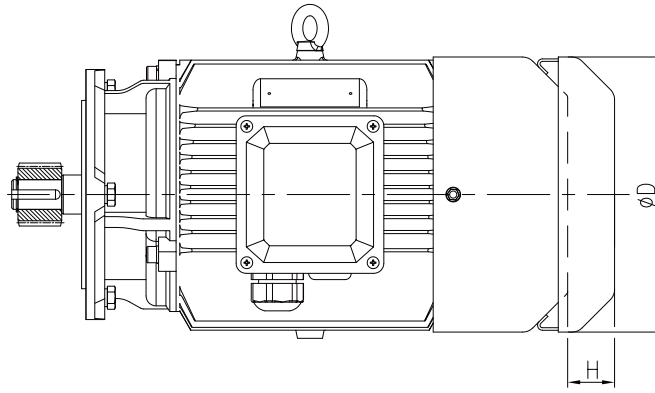

Frame Size	H63	H71	H80	H90	H100	H112	H132	H160	H180	H200	H225	H250	H280
D	124	139	159	176	199	220	259	314	356	398	446	485	547
H	25	30	30	35	40	40	40	60	60	70	70	80	80

10 Recommended Dimensions for Driven Equipment Shaft

10.1 Shrink disk

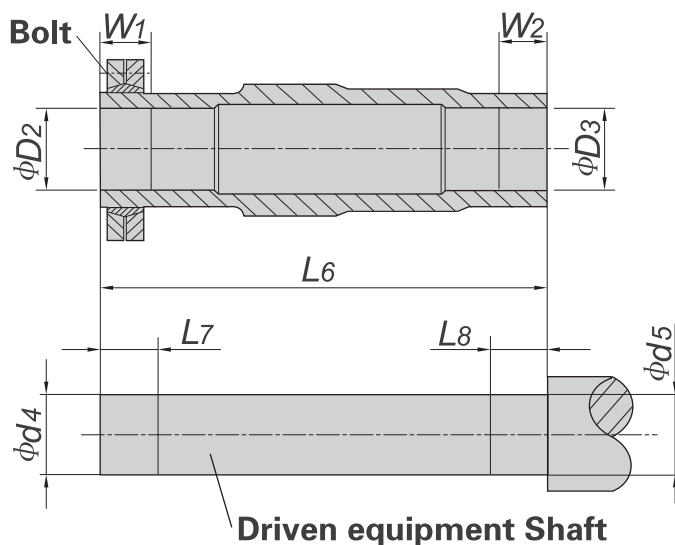

Size	D2	D3	d4	d5	L6	L7	L8	W1	W2	Type	Bolt	Weight
F202 F302	25H7	25H7	25h6	25h6	128	35	35	30	30	SP2-36×72	M6	0.5
F203 F303	30H7	30H7	30h6	30h6	146	35	25	30	20	SP2-44×80	M6	0.6
F204 F304	35H7	35H7	35h6	35h6	177	35	25	30	20	SP2-44×80	M6	0.6
F205 F305	40H7	40H7	40h6	40h6	195	40	30	35	25	SP2-50×90	M6	0.8
F206 F306	40H7	40H7	40h6	40h6	208	43	25	38	20	SP2-50×90	M6	0.8
F207 F307	50H7	50H7	50h6	50h6	241	41	35	36	30	SP2-62×110	M6	1.3
F208 F308	65H7	65H7	65h6	65h6	281	46	45	41	40	SP2-80×145	M8	1.9
F209 F309	75H7	75H7	75h6	75h6	345	60	55	55	50	SP2-90×155	M8	3.3
F210 F310	95H7	95H7	95h6	95h6	405	75	70	65	60	SP2-110×185	M10	5.9
F212 F312	105H7	105H7	105h6	105h6	485	95	80	85	70	SP2-140×230	M12	10
F215 F315	125H7	125H7	125h6	125h6	580	100	87	90	77	SP2-155×263	M12	15

10.2 Involute spline

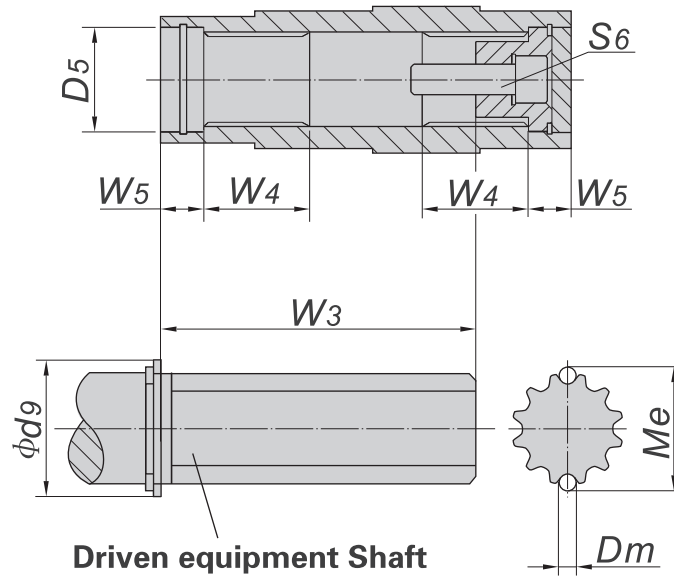

Size	D5	Dm	d9	Me	W3	W4	W5	S6
F202 F302	32	2.75	36	27.99	72	25	18	M10×30
F203 F303	37	2.75	42	33.03	85	25	18	M10×30
F204 F304	37	4	42	38.92	115	32	18	M10×30
F205 F305	42	4	47	38.92	125	42	25	M16×40
F206 F306	42	4	47	38.92	140	42	25	M16×40
F207 F307	55	4	62	54.13	160	52	23	M16×50
F208 F308	72	4	82	68.96	180	62	25	M20×60
F209 F309	72	4	90	74.15	240	72	25	M20×60
F210 F310	90	6	105	91	290	89	26	M20×60
F212 F312	100	6	120	101.05	380	92	28	M24×60
F215 F315	120	6	140	125.99	465	107	30	M24×70

11 Shaft End Centre Hole

Type C screw central hole in shaft end

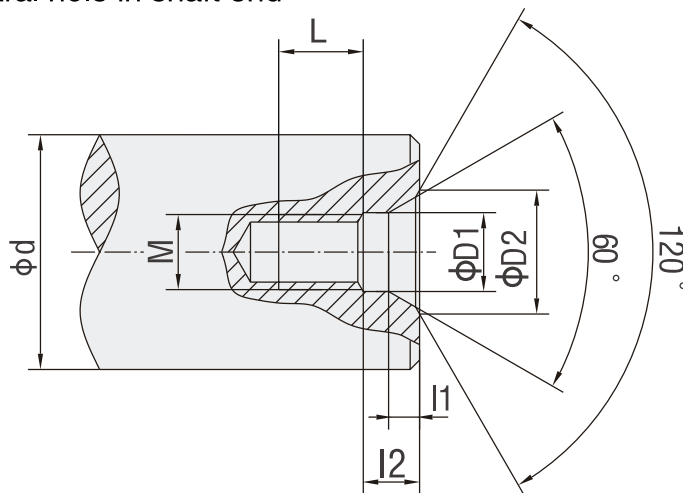

d	M	L	I2	I1	D1	D2
$7 < d \leq 10$	M3	10	2.6	1.8	3.2	5.8
$10 < d \leq 13$	M4	10	3.2	2.1	4.3	7.4
$13 < d \leq 16$	M5	10	4	2.4	5.3	8.8
$16 < d \leq 21$	M6	12	5	2.8	6.4	10.5
$21 < d \leq 24$	M8	12	6	3.3	8.4	13.2
$24 < d \leq 30$	M10	15	7.5	3.8	10.5	16.3
$30 < d \leq 38$	M12	20	9.5	4.4	13	19.8
$38 < d \leq 50$	M16	25	12	5.2	17	25.3
$50 < d \leq 85$	M20	30	15	6.4	21	31.3
$85 < d \leq 130$	M24	35	18	8	25	38
$130 < d \leq 225$	M30	45	18	11	31	48

12 Dimension of Parallel Key and Keyway

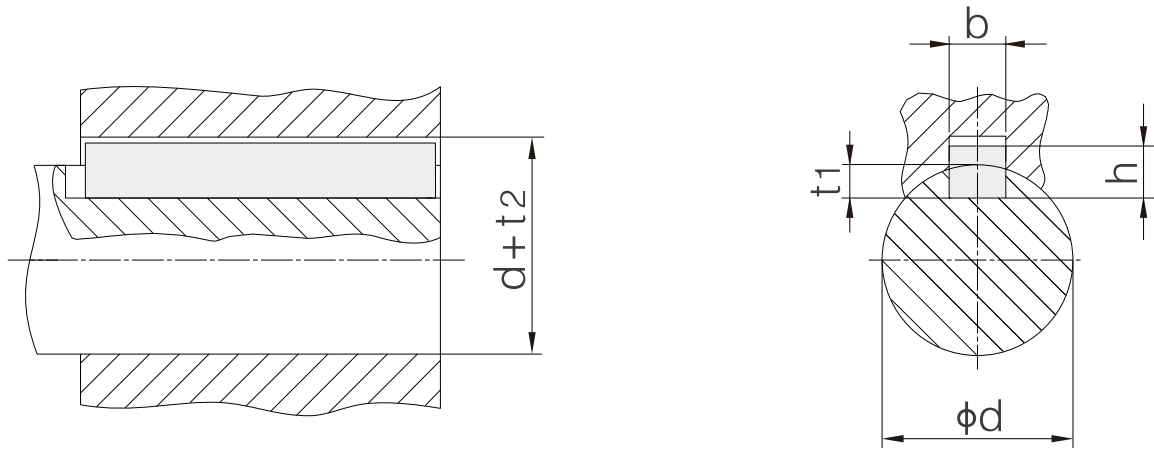

d	b	h	t ₁	d + t ₂
8 < d ≤ 10	3	3	1.8	d + 1.4
10 < d ≤ 12	4	4	2.5	d + 1.8
12 < d ≤ 17	5	5	3	d + 2.3
17 < d ≤ 22	6	6	3.5	d + 2.8
22 < d ≤ 30	8	7	4	d + 3.3
30 < d ≤ 38	10	8	5	d + 3.3
38 < d ≤ 44	12	8	5	d + 3.3
44 < d ≤ 50	14	9	5.5	d + 3.8
50 < d ≤ 58	16	10	6	d + 4.3
58 < d ≤ 65	18	11	7	d + 4.4
65 < d ≤ 75	20	12	7.5	d + 4.9
75 < d ≤ 85	22	14	9	d + 5.4
85 < d ≤ 95	25	14	9	d + 5.4
95 < d ≤ 110	28	16	10	d + 6.4
110 < d ≤ 130	32	18	11	d + 7.4
130 < d ≤ 150	36	20	12	d + 8.4
150 < d ≤ 170	40	22	13	d + 9.4
170 < d ≤ 200	45	25	15	d + 10.4
200 < d ≤ 230	50	28	17	d + 11.4
230 < d ≤ 260	56	32	20	d + 12.4

13 Oil

Mounting position Size	D1	D2	D3	D4	D5	D6
F202 F302	0.7	0.9	1	1	0.9	0.8
F203 F303	1.2	1.4	1.3	1.5	1.3	1.1
F204 F304	1.8	2.1	2.2	2.3	2.2	1.9
F205 F305	2.1	2.8	2.5	2.9	2.4	2.3
F206 F306	3.1	3.9	4.1	4.2	3.9	3.3
F207 F307	5.8	7.8	7.6	8.6	7.2	6.8
F208 F308	10.9	14.8	13.7	14.7	13.2	11.3
F209 F309	20	28	27	26	24	21
F210 F310	25	37	35	36	32	27
F212 F312	43	65	58	66	56	59
F215 F315	75	125	101	116	97	84

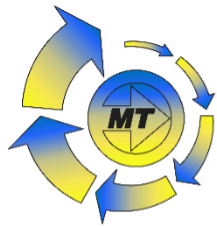

Distributors for Australia & New Zealand
MOTION TECHNOLOGIES PTY LIMITED



24/22-30 Northumberland Road
Caringbah NSW 2229 Australia
Phone: (02) 9524 4782

sales@motiontech.com.au
www.motiontech.com.au

© 08/08/2024