

BONENG

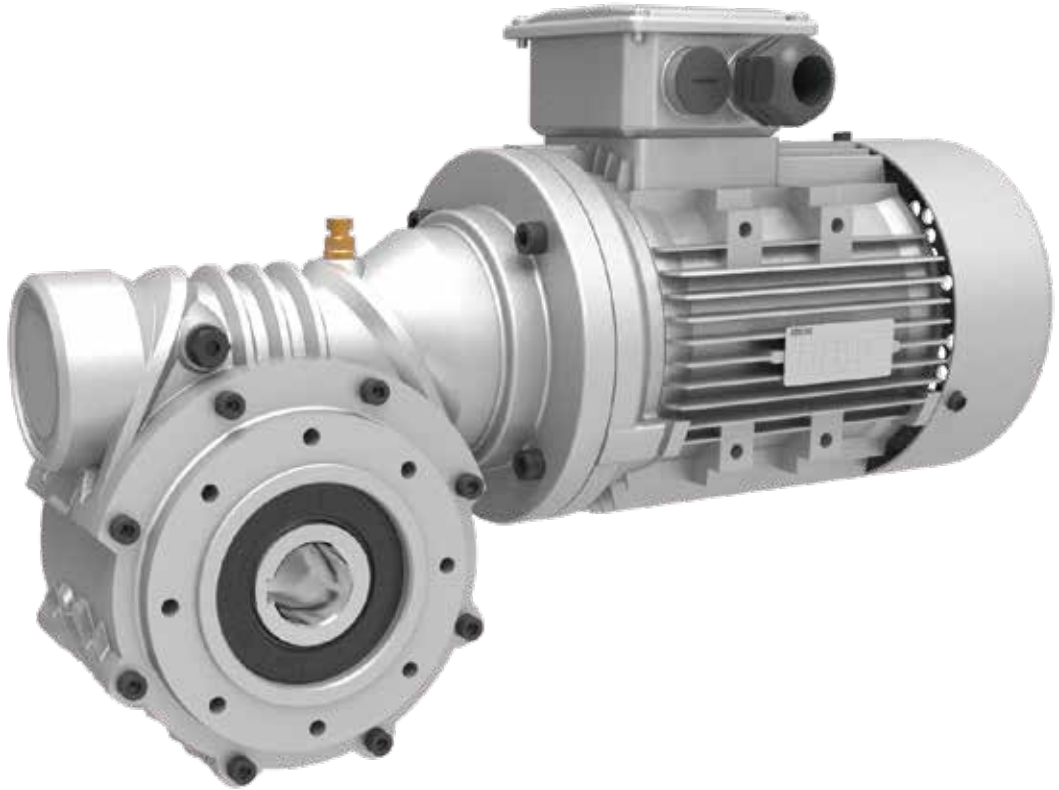

**R系列蜗轮
减速机**

**R Worm
Gear Units**

Modified date 08/2023
Selection Sample C05.0003

Boneng Transmission

www.motiontech.com.au

博能传动提升产业运行可靠·高效·精准和智能化!

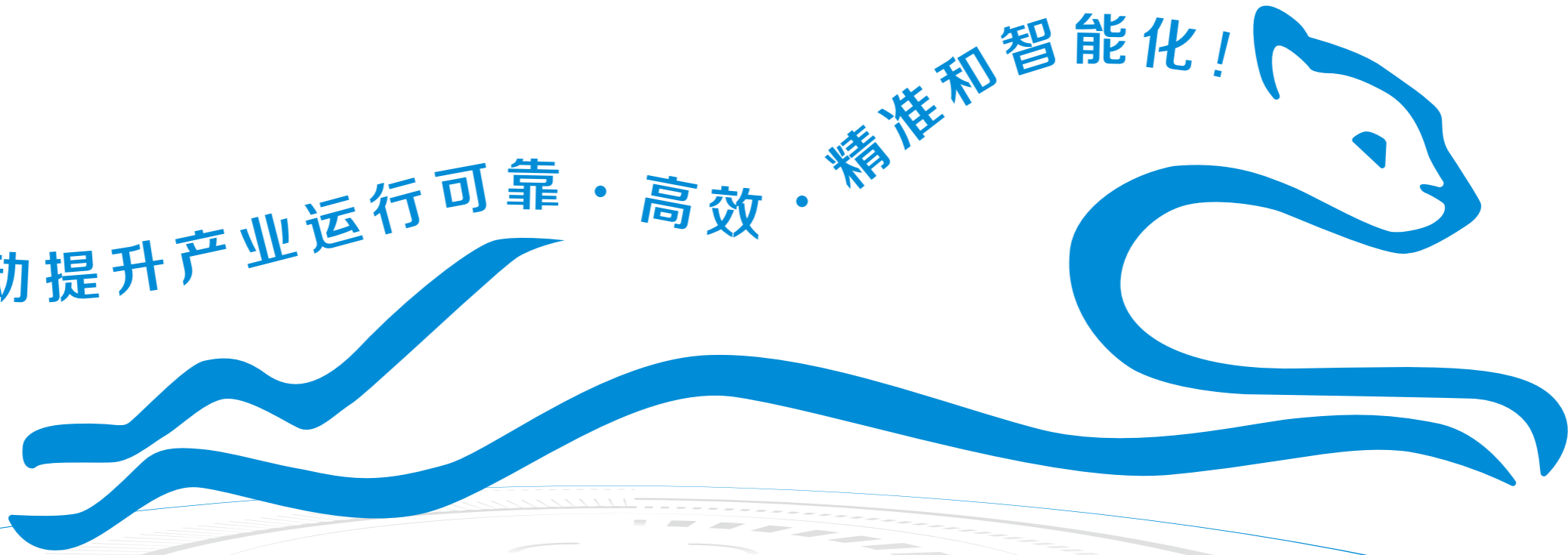

控制器/驱动器/马达/
齿轮马达/齿轮箱 Controller/ Drive/ Motor/
Gearmotor/ Gearbox

蜗轮减速机

博能公司在总结二十余年齿轮箱设计制造经验，分析和吸收国际上减速电机设计制造的先进技术的基础上，创新发展，推出新型R系列减速电机，以更好满足客户要求。

同国际上先进的减速电机和博能公司原有R系列减速电机相比，博能公司新型R系列减速电机具有：



Worm Gear Units

On the basis of summarizing gear units design and manufacturing experiences in the past twenty years, analyzing and absorbing advanced technology of international gear units motor production, Boneng Transmission makes innovative development, pushing forward new type R series gear motor to better satisfy customer requirements.

Compared with internationally advanced gear motor and the original R series gear motor of Boneng, the new type R series gear motor has the following characteristics:





- ◆ 独创的模块化设计，零部件通用最大化，便于国际化生产，库存少，供货周期短。
- ◆ 独创的模块化设计，功能附件的配置互换程度高，能灵活满足客户设备要求的各种结构及布置形式和不同的使用工况。
- ◆ 同向轴输出，蜗轮箱可串联使用，减少动力源。
- ◆ 采用德国进口蜗轮滚刀加工，优化蜗轮齿面接触区，传动精度高，承载能力大。
- ◆ 通过拟生态的外观设计，赋予产品运动和力量的天性内涵，体现了博能公司世界级的卓越产品设计理念，并拥有自主知识产权。
- ◆ 能以单级传动获得较大的传动比，且传动平稳，振动、冲击和噪音均小。
- ◆ 拥有底脚式、法兰式、轴装式等多种安装方式，能满足客户的不同安装方式要求。
- ◆ 蜗轮材质为锡青铜，蜗杆为合金钢经渗碳淬火后精密磨削；具有良好的抗胶合和耐磨的性能，使用寿命长。
- ◆ 氟橡胶密封件，具有优异的耐高温、防老化、耐磨损性能，在复杂和恶劣的工作环境中具有更高的安全性和更长的使用寿命。
- ◆ Unique modular design, general applications of components are maximized, which is convenient for international production, storage quantity is small, supplement circle is short.
- ◆ Unique modular design, allocation exchange degree of functional attachments flexibly satisfy various kinds of required structures, arrangement form and different working situations of customer equipment.
- ◆ Homodromous shaft output, worm box can be used together, thus reduce driving source.
- ◆ It applies Germany imported worm hob processing, which optimize worm gear face contact region. The transmission accuracy is high, bearing capacity is large.
- ◆ The appearance design shows world-wise product design idea of Boneng transmission, it owns intellectual property rights.
- ◆ It can get large transmission ratio with single level transmission, the transmission is stable, it owns foot mounting, flange mount, shaft mount, shaft mounting and various kinds of mounting methods, Vibration, impact and noise are low.
- ◆ It owns foot mounting, flange mounting, shaft mounting and various kinds of mounting methods, which can satisfy various kinds of mounting requirements of customers.
- ◆ The material of worm is tin bronze, the worm rod is alloy steel, which is grinded after carburizing and quenching; the material has good anti-gluing and anti-abrasion performances, the lifespan is long.
- ◆ Fluorous rubber sealing piece, with good high-temperature resistant, anti-aging and anti-abrasion performance, it is safer and with longer lifespan in complex and bad working environment.

注意事项！必须严格遵守以下各项！

Note: You must conform to the following instructions

- ◆ 样本中的结构示意图、外形图及其他附图只属范例。无严格比例要求。（未注尺寸单位均为mm）。
- ◆ 所注重量仅为平均值，并不具有约束力。
- ◆ 为防止意外事故发生，所有旋转部件均按照使用者所在国家和地区的安全规范由购置方加罩保护。
- ◆ 试车之前必须认真阅读使用说明书。
- ◆ 升降机在供货时已处于准运行状态，运行前需加注润滑油。
- ◆ 本样本中注油量只作为参考值，实际注油量应以油尺上的标记为准。
- ◆ 润滑油粘度应按升降机使用工况及使用环境温度选取。
- ◆ 只能采用国际知名品牌的润滑油。

- ◆ The structure scheme, appearance diagram and other attached diagrams in sample are examples, there is no strict proportion requirement. (The unmarked dimension units are mm).
- ◆ We can only refer to the marked weight in the manual.
- ◆ To prevent accidents, all the rotation parts should be added with protective covers according to local safety regulations and laws.
- ◆ Before testing, users should read instruction manual carefully.
- ◆ Jack has been tested before delivered, users should add lubrication oil before running.
- ◆ We can only refer to the marked oil in the manual. Actual oil filling level should be the same with the mark on oil immersion lens.
- ◆ Lubrication oil viscosity should be selected according to working conditions and the temperature of local environment.
- ◆ Users can only use high quality lubrication oil.

产品功能标识

Product Function Mark



油 镜



Oil glass



通气帽



Breather



进油孔



Oil filler



放油孔



Oil drain

目录

Contents

01.结构示意图·····	02	01.Structure Scheme···	02
02.型号表示方法·····	02	02.Type Designation·····	02
03.选型及举例·····	03	03.Type Selection and Example·····	03
04.传动能力表·····	05	04.Transmission Capacity·····	05
05.直联电机功率表·····	07	05.Directly connected motor power table···	07
06.允许径向力 $Fr_2(N)$ ·····	08	06.Permissible Radial Force on Shaft (Fr_2) (N)·····	08
07.外形尺寸图表·····	09	07.Outline Dimension Diagram·····	09
08.同向轴输出·····	14	08.Output Code of Ho- modromous Shaft is N·····	14
09.输入法兰与轴孔尺寸·	14	09. Dimensions of Input Flange and Shaft Bore·····	14
10.组合型·····	15	10.Combined type·····	15
11.附件·····	16	11.Attachment·····	16

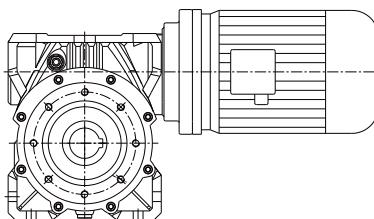

基本型: Basic type:

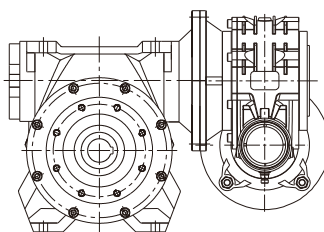

组合型: Combined type:

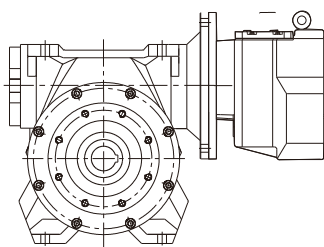

组合型: Combined type:

安装方位: Mounting Positions

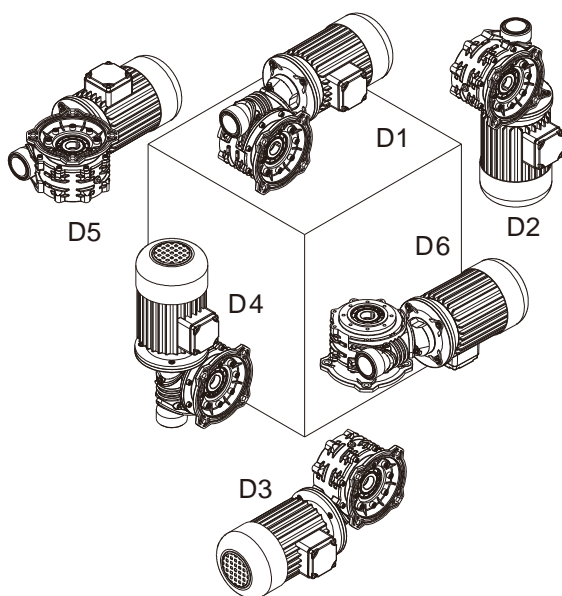

电机接线盒位置: Positions of Motor Terminal Box

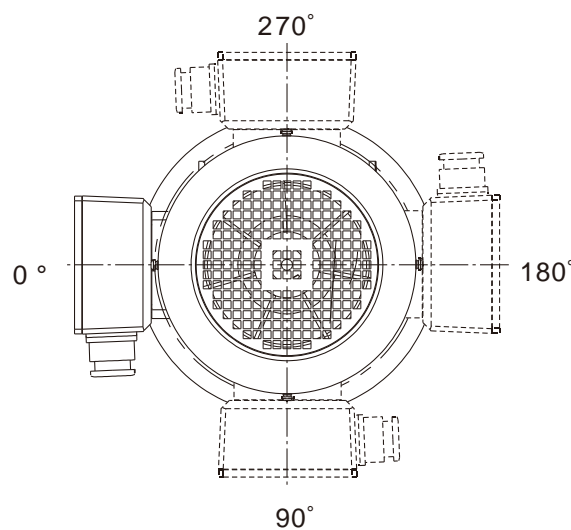

视角: 电机尾部 Visual angle: motor end

整机标配颜色: R050-R080: (RAL9006)
R100-R250: (RAL5015)

Standard colour of the machine: R050-R080: (RAL9006)
R100-R250: (RAL5015)

非标配颜色可按客户要求定制。

Non-standard colour can be customized according to customer requirements.

1 结构示意图:

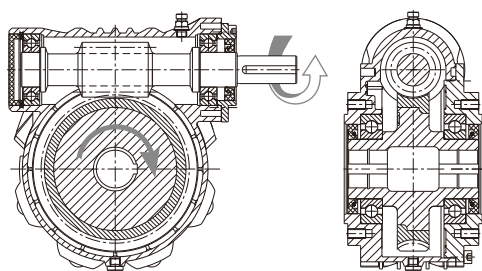

R铝合金箱体 R Aluminum alloy cabinet

1 Structure Scheme:

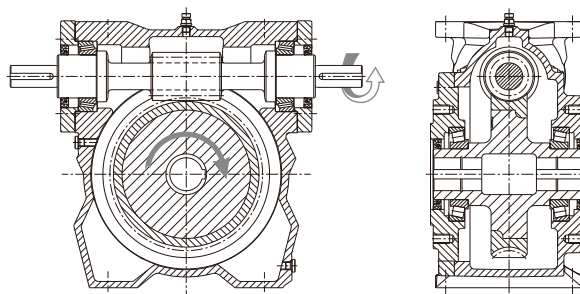

R铸铁箱体 R cast iron cabinet

2 型号表示方法:

02.Type Designation:

R系列

**机座号
安装形式**

H=卧式底脚安装
F=法兰安装
A=扭力臂安装

输出形式
(A/B/C/D/E/F/G/H)

**公称减速比
带同向输出轴**
(无此项不标)

输入部分
M 配电机用
S 配轴输入用
AF 配电机连接法兰用
(如AF71/AF80...)

附件

其它要求(安装方位)
(D1/D2/D3/D4/D...)

其它要求
(电机接线盒位置
0°/90°/180°/270°)

组合形式举例:R125HA/
CR47-355-M0.75+E30-
D1

组合形式举例:R125HA/
R063A-160-M1.5+E30-
D1

R series

**Foundation number
Mounting Mode**

H= Horizontal foot mounting
F= Flange mounting
A= Torque arm mounting

Output Mode
(A/B/C/D/E/F/G/H)

Nominal Ratio
With homodromous output shaft
(This item doesn't have non-standard type)

Input Part
M with motor
S with shaft input
AF with motor connection flange
(AF71/AF80...)

Accessories

Other requirements(mounting positions)
(D1/D2/D3/D4/D...)

Other requirements
(position of motor wiring box 0°/90°/180°/270°)

Combined-type Designation:
R125HA/CR47-355-M0.75+E30-D1

Combined-type Designation:
R125HA/R063A-160-M1.5+E30-D1

R 080 H A-30-N-M1.5+E30-D1-90

3 选型及举例

3 Type Selection and Example

序号	说明	代号	参数计算							
Serial number	Instruction	Codes	Parameters Calculation							
1	被驱动设备系数 Driven Machine Factor	f1	负荷性质 Load Characteristic	每天使用时间 (小时) Operating hours per day (h)						
				≤2	2~10	10~24				
			均匀负载 Uniform	1.00(1.00)	1.00(1.25)			1.25(1.50)		
			一般冲击 Moderate	1.00(1.25)	1.25(1.50)			1.50(1.75)		
			强烈冲击 Heavy	1.25(1.50)	1.50(1.75)			1.75(2.00)		
			注: 当每小时启动、停止次数≥10次, 请使用括号内数值。			Note: Apply values in the brackets when starting and stopping time per hour are less than 10 times				
2	环境温度系数 Ambient temperature factor	ft	负荷性质 Load Characteristic	环境温度 Ambient temperature						
				20	25	30	35	40	45	50
			均匀负载 Uniform	1.00	1.00	1.00	1.03	1.06	1.12	1.20
			一般冲击 Moderate	1.00	1.01	1.02	1.06	1.12	1.16	1.30
	强烈冲击 Heavy	1.00	1.02	1.04	1.10	1.17	1.20	1.40		
3	输入转速 Input speed	n1	≤1800r/min 更高转速请咨询			≤1800r/min Consult us if higher speed required.				
4	确定减速比 Calculation of the ratio	i	i=n1/n2							
5	传动效率 Transmission efficiency	η	见05页 (传动能力表)			See the table of transmission capacity on P05				
6	以被动设备所需的扭矩或功率, 确定齿轮马达的输入功率 Calculation of the input power of the gear motor on basis of the torque and power required by the driven machine.	P1	P1=T2·n1/(9550·i·η) 或 P1=P2/η							
7	根据计算, 查传动能力表, 确定齿轮马达规格, 直联马达时需查直联马达功率表 Determination of gear motor type referring to the table of transmission capacity after calculation. For directly-connected motor, require to refer to directly-connected motor power table.	T2N、P1N	T2N≥T2·f1·ft 或 P1N≥P1·f1·ft							
8	径向力、轴向力校核 Check the radial and axial forces on the shafts	Fr1/Fr2 Fa1/Fa2	见08页, R系列Fr2表。			See Fr2 table on P08				
9	确认润滑方式 Determination of lubrication system		一般采用飞溅润滑 (R50~R80脂润滑)			Generally Apply Splash Lubrication				

序号	说明	代号	参数计算
Serial number	Instruction	Codes	Parameters Calculation
10	确认冷却方式 Determination of cooling system		自然冷却 Natural Cooling
11	按型号表示方法确定各项 Determination of every item included in the type designation		型号表示方法见第02页 For details about type designation, see P02.
12	一般环境条件 Normal ambient conditions		环境温度: -10至40°C, 空旷场地通风良好, 海拔高度1000米一下, 一般工厂灰尘。 环境温度: -10至40°C, 空旷场地通风良好, 海拔高度1000米一下, 一般工厂灰尘。
13	特殊环境条件 Special ambient conditions		高温、低温、灰尘多、化学作用(例: 酸碱等), 露天(直接日照、冰、水淋等), 请咨询。 For higher or lower temperature, dusty sites, chemical reaction (acids, alkaline, etc), or open field (sunlight, ice, rain, etc), please consult us!

选型举例	Examples of type selection
<p>1) 减速电机</p> <p>已知条件:</p> <p>1 被驱动设备所需功率$P_2=5\text{kW}$所需转速$n_2=95\text{ r/min}$; 2 普通电机: 4极, 转速$n_1=1450\text{r/min}$; 3 负荷性质: 一般冲击, 工作12小时/天, 启动频率1次/小时, 环境温度20°C; 4 安装输出形式: 单向实心输出轴与法兰同向, 法兰安装, 安装方位D4, 接线盒位置180°</p> <p>选型步骤:</p> <p>1、根据负荷性质表可得出被驱动设备系数$f_1=1.5$, $f_t=1$; 2、确定速比$i_N:=n_1/n_2=1450/95=15.3$, 取公称速比$i_N=15$; 3、计算输入功率并确定电机功率(查得蜗轮箱传动效率$\eta=84\%$): $P_1=P_2/\eta=5/0.84=5.95\text{kW}$, 取电机功率$7.5\text{kW}$; 4、确定减速电机额定功率$P_{1N}: P_{1N} \geq P_1 \cdot f_1 \cdot f_t = 5.95 \times 1.5 \times 1 = 8.925\text{ kW}$; 5、根据已知条件和以上数据, 根据传动能力表可初选减速机, 电机型号为: R125FA-15-M7.5-D4-180</p> <p>2) 齿轮箱</p> <p>已知条件:</p> <p>1、被驱动设备所需扭矩$T_2=75\text{N}\cdot\text{m}$, 所需转速$n_2=73\text{r/min}$; 2、用户自配电机的要求: 4极, 转速$n_1=1450\text{r/min}$; 3、负荷性质: 一般冲击, 工作16小时/天, 连续运转, 环境温度20°C; 4、安装输出形式: 平键空心轴输出, 底脚安装, 安装方位D1。</p> <p>选型步骤:</p> <p>1、根据负荷性质表可得出被驱动设备系数$f_1=1.5$, $f_t=1$; 2、确定速比$i_N:=n_1/n_2=1450/73=19.86$, 取公称速比$i_N=20$; 3、确定减速机额定扭矩$T_2N$及额定功率$P_{1N}$ (查表得出蜗轮箱传动效率$\eta=81\%$): $T_2N \geq T_2 \cdot f_1 \cdot f_t = 75 \times 1.5 = 112.5\text{ N}\cdot\text{m}$; $P_{1N} \geq P_1 \cdot f_1 \cdot f_t = T_2 \cdot f_1 \cdot n_1 / (9550 \cdot i_N \cdot \eta) = 75 \times 1.5 \times 1 \times 1450 / (9550 \times 20 \times 0.81) = 1.05\text{ kW}$; 根据传动能力表可得出R63满足要求 ($T_2N=116\text{ N}\cdot\text{m}$, $P_{1N}=1.12\text{ kW}$); 4、确定输入部分: 根据 $P_{1N} \geq P_1 \geq T_2 \cdot n_1 / (9550 \cdot i_N \cdot \eta) = 75 \times 1450 / (9550 \times 20 \times 0.81) = 0.7\text{ kW}$; 用户自配的电机功率取$P_1=0.75\text{ kW}$, 查14页输入法兰与轴孔尺寸选AF80即可; 5、根据已知条件和以上数据, 可初选出减速箱型号为: R063HG-20-AF80-D1</p>	<p>1) Gear motor</p> <p>Known Criteria:</p> <p>1. The power required by the driven machine $P_2=5\text{kW}$, speed needed $n_2=95\text{r/min}$ 2. Common motor: 4-pole, speed $n_1=1450\text{r/min}$ 3. Loading characteristics: moderate impact, working 12 hours/d and starting frequency 1 time/h, ambient temperature 20°C 4. Mounting output mode: Unidirectional solid output shaft on the same side with flange, flange-mounted, mounting position D4, terminal box position 180°.</p> <p>Selection Steps:</p> <p>1. By referring to the table of Loading Characteristic, we get the driven machine factor $f_1=1.5$, and $f_t=1$ 2. Calculation of the ratio: As $i_N=n_1/n_2=1450/95=15.3$, nominal ratio $i_N=15$ is appropriate 3. Calculation of the input power and determination of the motor power (transmission efficiency of worm box $\eta=84\%$): $P_1=P_2/\eta=5/0.84=5.95\text{kW}$, so 7.5kW motor is selected. 4. Determination of the rated power of the gear motor P_{1N}: $P_{1N} > P_1 \cdot f_1 \cdot f_t = 5.95 \times 1.5 \times 1 = 8.925\text{kW}$ 5. The type selected according to the table of transmission capacity, known conditions and the above data: R125FA-15-M7.5-D4-180</p> <p>2) Gear Unit</p> <p>Known Criteria:</p> <p>1. The torque required by the driven machine $T_2=75\text{N}\cdot\text{m}$ and speed required $n_2=73\text{r/min}$ 2. The requirement of the motor supplied by the users: 4-pole, speed $n_1=1450\text{r/min}$ 3. Loading characteristic: moderate impact, operating 16h/d, Continuous running, environment temperature 20°C 4. Mounting output mode: hollow output shaft with parallel key, foot-mounted, mounting position D 1</p> <p>Selection steps:</p> <p>1. By referring to the table of loading Characteristic, we get the driven machine factor $f_1=1.5$, and $f_t=1$. 2. Calculation of the ratio i_N: As $i_N=n_1/n_2=1450/73=19.86$, nominal ratio $i_N=20$ is appropriate 3. Determination of the nominal torque T_2N and rated power P_{1N} of the gear unit (transmission efficiency of worm box $\eta=81\%$): $T_2N > T_2 \cdot f_1 \cdot f_t = 75 \times 1.5 = 112.5\text{ N}\cdot\text{m}$; $P_{1N} > P_1 \cdot f_1 \cdot f_t = T_2 \cdot f_1 \cdot n_1 / (9550 \cdot i_N \cdot \eta) = 175 \times 1.5 \times 1 \times 1450 / (9550 \times 20 \times 0.81) = 1.05\text{ kW}$ In the table of Transmission Capacity, R63 meets the requirements ($T_2N=116\text{ N}\cdot\text{m}$, $P_{1N}=1.12\text{ kW}$) 4. Determination of the input part: As $P_{1N} > P_1 = T_2 \cdot n_1 / (9550 \cdot i_N \cdot \eta) = 75 \times 1450 / (9550 \times 20 \times 0.81) = 0.7\text{ kW}$ and power of the user-supplied motor is specified as 0.75 kW, in the table of dimensions of input flange and shaft bore on P14, AF80 is selected. 5. The type is selected according to known criteria and data R063HG-20-AF80-D1</p>

4 传动能力表:

4 Transmission Capacity

4.1 基本型:

4.1 Basic type

	n ₁ (r/min)	i _N	η	R050				R063				R080				R100			
				n _{2N} (r/min)	T _{2N} (N·m)	i _{ex}	P _{1N}	n _{2N} (r/min)	T _{2N} (N·m)	i _{ex}	P _{1N}	n _{2N} (r/min)	T _{2N} (N·m)	i _{ex}	P _{1N}	n _{2N} (r/min)	T _{2N} (N·m)	i _{ex}	P _{1N}
	1450	7	0.87	220	37	6.60	0.98	234	69	6.2	1.94	177	230	8.2	4.90	250	315	5.8	9.5
		10	0.84	136	57	10.7	0.97	140	110	10.3	1.92	136	255	10.7	4.32	136	465	10.7	7.9
		15	0.84	101	62	14.3	0.78	98.9	114	14.7	1.40	101	235	14.3	2.96	101	450	14.3	5.7
		20	0.81	77.7	69	18.7	0.69	75.0	116	19.3	1.12	73.7	230	19.7	2.19	77.7	430	18.7	4.32
		30	0.79	45.3	80	32	0.48	46.8	131	31	0.81	45.3	270	32	1.62	45.3	555	32	3.33
		45	0.75	32.2	62	45	0.28	33.7	106	43	0.50	33.7	235	43	1.11	33.0	435	44	2.00
		60	0.71	25.4	53	57	0.20	23.8	103	61	0.36	25.0	215	58	0.79	25.4	405	57	1.52

4.2 R../R..组合型:

4.2 R../R..Combined type

	n ₁ (r/min)	n _{2N} (r/min)	i _N	η	R050./R050			R063./R050			R080./R050		
					T _{2N} (N·m)	i _{ex}	P _{1N}	T _{2N} (N·m)	i _{ex}	P _{1N}	T _{2N} (N·m)	i _{ex}	P _{1N}
	1450	14.5	100	0.55	78	94.6	0.23	141	96.8	0.40	230	94.6	0.67
		9.06	160	0.54	78	152.9	0.14	141	156.4	0.25	230	152.9	0.42
		7.25	200	0.52	78	205.4	0.11	141	210.2	0.20	230	205.4	0.33
		4.08	355	0.48	111	341.3	0.10	188	330.7	0.18	325	341.3	0.30
		3.22	450	0.45	111	458.7	0.08	188	444.3	0.14	325	458.7	0.24
		2.30	630	0.40	111	597.3	0.07	188	578.7	0.12	325	597.3	0.21
		1.45	1000	0.35	111	1024	0.05	188	992.0	0.08	325	1024	0.14
		1.04	1400	0.30	122	1440	0.04	205	1376	0.08	355	1376	0.13
		0.73	2000	0.30	122	2025	0.03	205	1935	0.05	355	1935	0.09
		0.58	2500	0.24	122	2565	0.03	205	2745	0.05	355	2610	0.09

4.3 R../CR..组合型:

4.3 R../CR..Combined type:

i_N:100-710

	n ₁ (r/min)	n _{2N} (r/min)	i _N	η	R125./CR47			R160./CR67			R200./CR77			R250./CR87		
					T _{2N} (N·m)	i _{ex}	P _{1N}	T _{2N} (N·m)	i _{ex}	P _{1N}	T _{2N} (N·m)	i _{ex}	P _{1N}	T _{2N} (N·m)	i _{ex}	P _{1N}
	1450	14.5	100	0.72	1200	100.8	2.51	2300	101.5	4.78	4350	97.0	9.5	6700	99.1	14.3
		12.9	112	0.70	1200	110.9	2.35	2300	112.8	4.42	4350	107.8	8.8	6700	114.1	12.7
		11.6	125	0.70	1300	128.3	2.20	2450	128.9	4.12	4500	120.5	8.1	7200	127.0	12.3
		9.06	160	0.66	1400	153.0	2.11	2650	154.0	3.96	4900	151.4	7.4	7500	155.8	11.1
		8.06	180	0.66	1400	175.6	1.83	2650	174.7	3.49	4900	171.9	6.6	7500	173.5	9.9
		6.47	224	0.66	1450	219.8	1.52	2800	228.4	2.82	5200	230.2	5.2	8000	223.1	8.2
		5.80	250	0.66	1450	241.9	1.38	2800	253.8	2.54	5200	255.7	4.68	8000	256.7	7.2
		5.18	280	0.66	1500	280.0	1.23	2950	290.1	2.34	5600	285.9	4.51	8500	285.8	6.8
		4.08	355	0.65	1600	333.8	1.12	3050	346.5	2.06	5800	359.0	3.77	8800	350.5	5.9
		3.63	400	0.64	1600	383.0	0.99	3050	393.0	1.84	5800	407.7	3.38	8800	390.4	5.3
		3.22	450	0.64	1600	421.8	0.90	3050	437.3	1.65	5800	452.5	3.04	8800	450.1	4.64
		3.02	480	0.63	1650	458.9	0.87	3200	472.5	1.63	6000	464.6	3.11	9100	477.9	4.59
		2.59	560	0.62	1650	526.7	0.77	3200	536.0	1.46	6000	527.6	2.79	9100	532.4	4.19
		2.42	600	0.62	1650	579.9	0.70	3200	596.3	1.31	6000	585.6	2.51	9100	613.8	3.63
		2.30	630	0.62	1650	675.0	0.60	3200	666.5	1.18	6000	656.0	2.24	9100	683.1	3.26
2.04	710	0.60	1650	751.5	0.56	3200	749.3	1.08	6000	738.3	2.06	9100	765.0	3.01		

R125				R160				R200				R250			
n_{2N} (r/min)	T_{2N} (N·m)	i_{ex}	P_{1N}	n_{2N} (r/min)	T_{2N} (N·m)	i_{ex}	P_{1N}	n_{2N} (r/min)	T_{2N} (N·m)	i_{ex}	P_{1N}	n_{2N} (r/min)	T_{2N} (N·m)	i_{ex}	P_{1N}
186	650	7.8	14.5	/	/	/	/	/	/	/	/	/	/	/	/
136	720	10.7	12.2	/	/	/	/	/	/	/	/	/	/	/	/
98.9	745	14.7	9.2	98.9	1500	14.7	18.5	101	2500	14.3	31.5	98.9	3950	14.7	48.7
77.7	715	18.7	7.2	/	/	/	/	/	/	/	/	/	/	/	/
45.3	835	32	5.0	43.9	1600	33	9.3	42.6	3050	34	17.2	43.9	5000	33	29.1
33.0	765	44	3.52	32.2	1550	45	7.0	33.0	2900	44	13.3	32.2	5050	45	22.7
25.4	685	57	2.57	25.0	1450	58	5.3	/	/	/	/	/	/	/	/

R100./R050			R125./R063			R160./R080			R200./R100			R250./R125		
T_{2N} (N·m)	i_{ex}	P_{1N}	T_{2N} (N·m)	i_{ex}	P_{1N}	T_{2N} (N·m)	i_{ex}	P_{1N}	T_{2N} (N·m)	i_{ex}	P_{1N}	T_{2N} (N·m)	i_{ex}	P_{1N}
405	94.6	1.18	1200	90.9	3.64	2300	120.3	5.3	4350	83.1	14.4	6700	114.4	16.2
405	152.9	0.74	1300	151.6	2.28	2450	156.4	4.40	4500	152.9	8.3	7200	156.4	12.9
405	205.4	0.58	1450	215.1	2.12	2800	210.2	3.89	5200	205.4	7.4	8000	215.1	10.9
570	341.3	0.53	1500	330.7	1.34	2950	352.0	2.65	5500	362.7	4.80	8500	352	7.6
570	458.7	0.42	1650	469.3	1.24	3200	473.0	2.28	6000	487.3	4.15	9100	484	6.3
570	597.3	0.36	1650	618.7	0.99	3200	649.0	1.87	6000	634.7	3.59	9100	616	5.6
570	1024	0.24	1650	992.0	0.72	3200	1056	1.31	6000	1088	2.39	9100	1056	3.74
570	1408	0.20	1650	1364	0.60	3200	1440	1.12	6000	1408	2.16	9100	1440	3.20
625	1980	0.16	1650	1892	0.42	3200	1935	0.84	6000	1936	1.57	9100	1980	2.33
625	2565	0.15	1650	2451	0.42	3200	2494	0.81	6000	2508	1.51	9100	2565	2.24

$i_N: 800-5000$

n_1 (r/min)	n_{2N} (r/min)	i_N	η	R125./CR47			R160./CR67			R200./CR77			R250./CR87		
				T_{2N} (N·m)	i_{ex}	P_{1N}	T_{2N} (N·m)	i_{ex}	P_{1N}	T_{2N} (N·m)	i_{ex}	P_{1N}	T_{2N} (N·m)	i_{ex}	P_{1N}
1450	1.81	800	0.6	1650	841.7	0.50	3200	848.7	0.95	6000	835.1	1.82	9100	861.3	2.67
	1.61	900	0.6	1650	893.6	0.47	3200	930.6	0.87	6000	914.8	1.66	9100	935.6	2.46
	1.30	1120	0.6	1650	1083	0.39	3200	1107	0.73	6000	1089	1.39	9100	1114	2.07
	1.16	1250	0.6	1650	1218	0.34	3200	1230	0.66	6000	1214	1.25	9100	1245	1.85
	1.04	1400	0.6	1650	1452	0.29	3200	1467	0.55	6000	1457	1.04	9100	1485	1.55
	0.91	1600	0.6	1650	1668	0.25	3200	1683	0.48	6000	1655	0.92	9100	1686	1.37
	0.81	1800	0.58	1650	1836	0.24	3200	1854	0.45	6000	1837	0.86	9100	1872	1.27
	0.73	2000	0.56	1650	2137	0.21	3200	2157	0.40	6000	2057	0.79	9100	2096	1.18
	0.58	2500	0.54	1650	2670	0.17	3200	2691	0.33	6000	2618	0.64	9100	2669	0.96
	0.52	2800	0.52	1650	2974	0.16	3200	3002	0.31	6000	2917	0.60	9100	2997	0.89
	0.46	3150	0.5	1650	3274	0.15	3200	3305	0.29	6000	3238	0.56	9100	3327	0.83
	0.41	3550	0.48	1650	3811	0.14	3200	3847	0.26	6000	3626	0.52	9100	3726	0.77
	0.36	4000	0.46	1650	4243	0.13	3200	4283	0.25	6000	4068	0.49	9100	4194	0.72
	0.32	4500	0.44	1650	4752	0.12	3200	4797	0.23	6000	4616	0.45	9100	4743	0.66
0.29	5000	0.4	1650	5047	0.12	3200	5094	0.24	6000	5060	0.45	9100	5198	0.66	

5 直联电机功率表:

5 Directly connected motor power table

		R50直联电机功率表 R50 Directly connected motor power table										R63直联电机功率表 R63 Directly connected motor power table											
$P_m(kW)$	i_N	0.12	0.18	0.25	0.37	0.55	0.75	1.1	1.5	2.2	3	4	0.12	0.18	0.25	0.37	0.55	0.75	1.1	1.5	2.2	3	4
7																							
10																							
15																							
20																							
30																							
45																							
60																							

		R80直联电机功率表 R80 Directly connected motor power table										R100直联电机功率表 R100 Directly connected motor power table											
$P_m(kW)$	i_N	0.25	0.37	0.55	0.75	1.1	1.5	2.2	3	4	5.5	7.5	0.55	0.75	1.1	1.5	2.2	3	4	5.5	7.5	11	14
7																							
10																							
15																							
20																							
30																							
45																							
60																							

		R125直联电机功率表 R125 Directly connected motor power table										R160直联电机功率表 R160 Directly connected motor power table											
$P_m(kW)$	i_N	0.75	1.1	1.5	2.2	3	4	5.5	7.5	11	15	18.5	1.1	1.5	2.2	3	4	5.5	7.5	11	15	18.5	22
7																							
10																							
15																							
20																							
30																							
45																							
60																							

		R200直联电机功率表 R200 Directly connected motor power table										R250直联电机功率表 R250 Directly connected motor power table											
$P_m(kW)$	i_N	3	4	5.5	7.5	11	15	18.5	22	30	37	45	7.5	11	15	18.5	22	30	37	45	55	75	90
7																							
10																							
15																							
20																							
30																							
45																							
60																							

1. 符号表示可直联电机;
2. 符号表示可直联电机 (电机功率大于减速机的额定输入功率, 即 $P_1 > P_{iN}$);
3. 符号表示不可直联电机;
4. 电机功率的选择应符合相应的被驱动设备系数及选型规定;
5. 电机为4极电机。

1. Symbol means it can be connected with motor directly
2. Symbol means it can be connected with motor directly (motor power larger than rated input power of gear unit, that is $P > P_{iN}$)
3. Symbol means it can't be connected with motor that is.
4. The selection of motor power should conform to relevant driven equipment coefficient and selection regulation.
5. The motor is 4-pole motor

6 允许径向力Fr2(N):

R50~80系列输出轴径向力Fr2表

6 Permissible Radial Force on Shaft (Fr2)(N)

R50~80Series Output Shaft Radial force Fr2 Table

n _{2N} (r/min)		Fr ₂ (N)		
输出转速范围	output speed range	R 50	R 63	R 80
200	315	560	810	/
180	200	940	1250	1810
160	180	985	1280	2000
125	160	1120	1550	2280
100	125	1200	1680	2400
90	100	1300	1930	2930
80	90	1430	2000	3200
63	80	1530	2180	3410
50	63	1690	2400	3800
40	50	1740	2650	4060
31.5	40	1970	2940	4670
25	31.5	2180	3220	5250
20	25	2480	3360	5250
≤20		2520	3760	5250

R100~250系列输出轴径向力Fr2表

R100~250Series Output Shaft Radial force Fr2 Table

n _{2N} (r/min)		Fr ₂ (N)				
输出转速范围	output speed range	R100	R125	R160	R200	R250
160	250	1340	1230	/	/	/
100	160	2160	2920	8120	/	/
80	100	2790	3780	9990	19500	30320
63	80	3340	4640	11310	21300	33890
50	63	3610	5160	/	/	/
40	50	3880	5400	13730	25200	40600
31.5	40	4560	6360	14700	25200	44040
25	31.5	4920	6960	14700	25200	47000
20	25	5540	7350	14700	25200	47000
≤20		6300	7350	/	/	/

7 外形尺寸图表:

7 Outline Dimension Diagram:

R.50~R.80

	R050	R063	R080
A	85	103	112
A1	70	85	90
B	120	144	172
B1	80	100	120
b	8	8	10
b1	5	6	8
C	7	8	10
C2	8	8	10
D	25H7	25H7	32H7
d	25k6	25k6	32k6
d1	14k6	19k6	24k6
E	50	50	80
E1	30	40	50
E2	68	70	89
F	68.5	80	95
f2	5	5	5
f3	3	3	3
G	43.5	53	57
G1	26	28	39
H	144	174	209
H1	36	42	48
h	60	72	86
h1	50	63	80
K1	104	130	155
K2	20	22	26
L1	78	100	121
L2	72	88	104
L3	60	73	87
M2	130	130	165
M3	85	95	115
N2	110H7	110H7	130H7
N3	70h7	80h7	95h7
n3	4	8	8
P2	160	160	200
P3	100	110	134
P4	119		170
Q	85	104	112
Q1	101	120	132
Q4	18	18	20
Q5	30	31	37
S	9	9	11
S2	9	9	11
S3	M8	M8	M8
T	28.3	28.3	35.3
t	28	28	35
t1	16	21.5	27
Weight (kg)	3	5.4	8.8

R...H底脚式安装
(可用于扭力臂安装)

R...H foot-mounted (Applicable for torque arm-mounting)

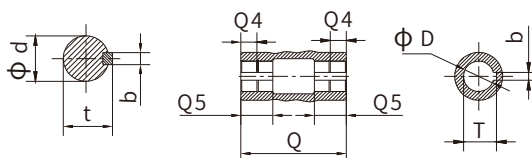
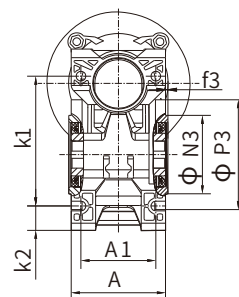
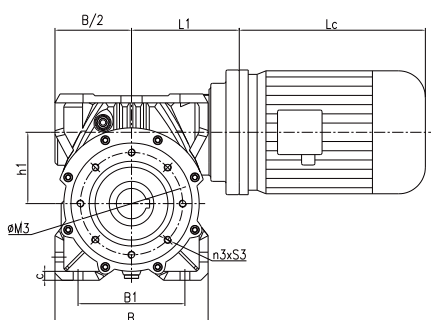
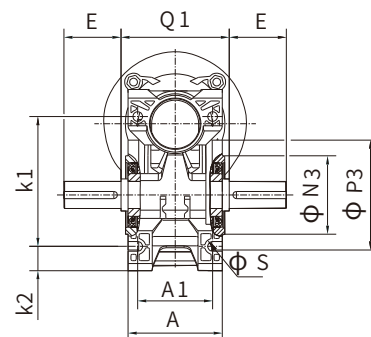
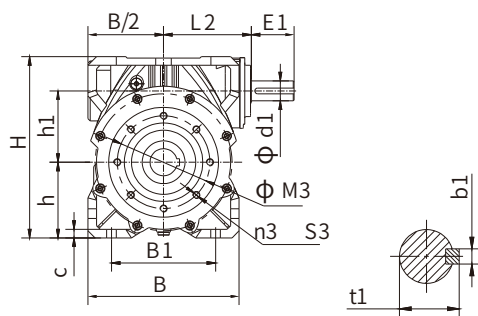

输出形式:

Output Mode:

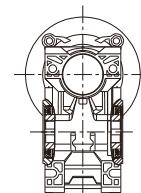
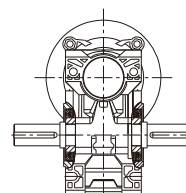
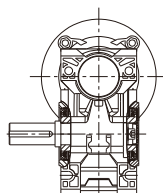
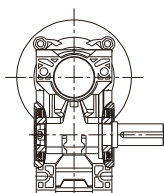

A

B

C

G

1. 要求带花键空心轴和锁紧盘空心轴输出时请来电咨询。
2. *重量不含电机和润滑油。
3. Lc见电机样本。

1. For hollow shaft with spline hollowshaft or lockingplate hollow shaft, please consultus.
2. *Weight of motor and lubricationoil are notincluded.
3. Lc can be seen on motor sample.

7 外形尺寸图表:

7 Outline Dimension Diagram:

R.50~R.80

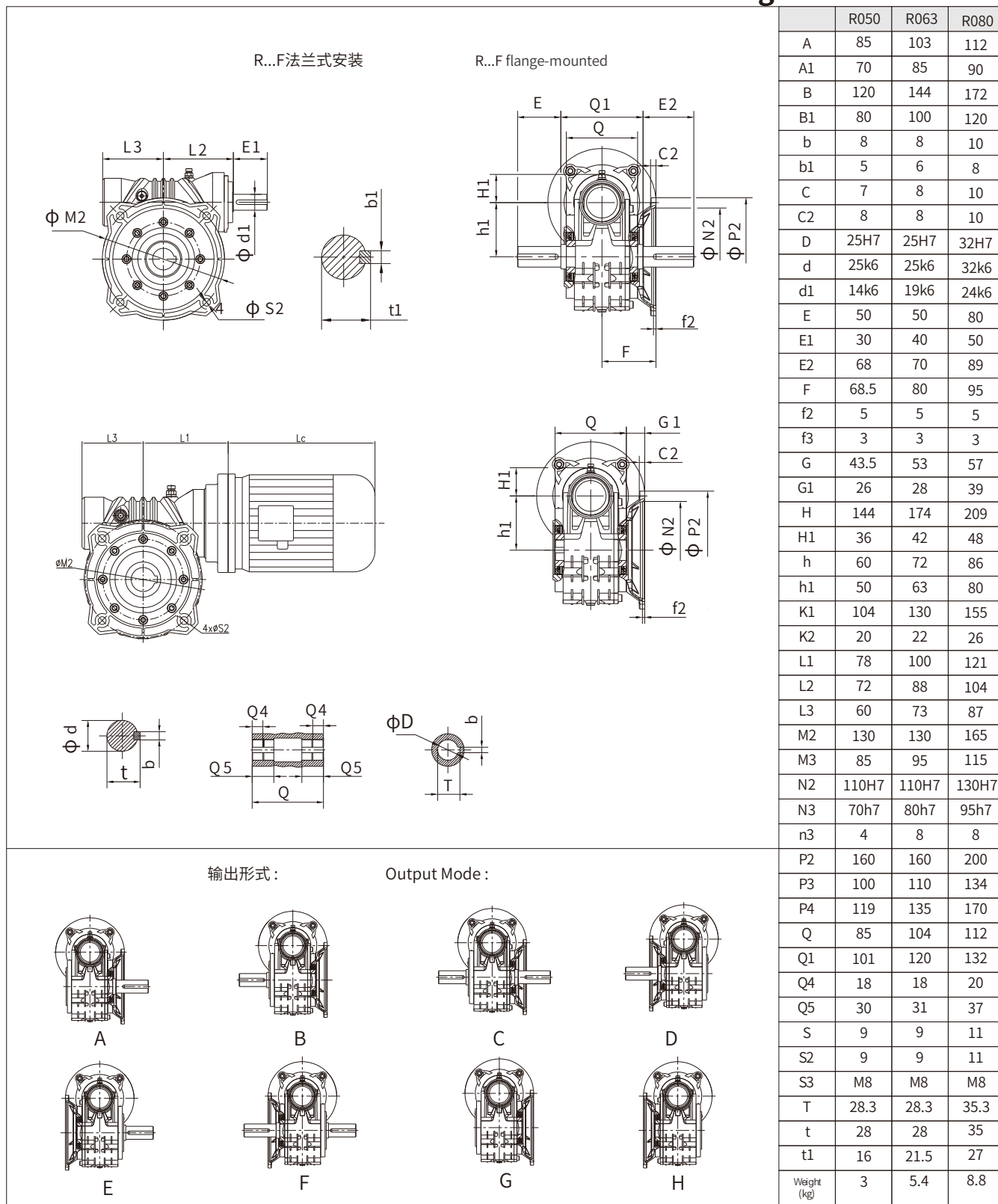

⚠ 1.要求带花键空心轴和锁紧盘空心轴输出时请来电咨询。
2.*重量不含电机和润滑油。
3.Lc见电机样本。

⚠ 1.For hollow shaft with spline hollowshaft or lockingplate hollow shaft, please consultus.
2.*Weight of motor and lubricationoil are notincluded.
3. Lc can be seen on motor sample.

7 外形尺寸图表:

7 Outline Dimension Diagram:

R.50~R.80

	R050	R063	R080
A	85	103	112
A1	70	85	90
B	120	144	172
B1	80	100	120
b	8	8	10
b1	5	6	8
C	7	8	10
C2	8	8	10
D	25H7	25H7	32H7
d	25k6	25k6	32k6
d1	14k6	19k6	24k6
E	50	50	80
E1	30	40	50
E2	68	70	89
F	68.5	80	95
f2	5	5	5
f3	3	3	3
G	43.5	53	57
G1	26	28	39
H	144	174	209
H1	36	42	48
h	60	72	86
h1	50	63	80
K1	104	130	155
K2	20	22	26
L1	78	100	121
L2	72	88	104
L3	60	73	87
M2	130	130	165
M3	85	95	115
N2	110H7	110H7	130H7
N3	70h7	80h7	95h7
n3	4	8	8
P2	160	160	200
P3	100	110	134
P4	119	135	170
Q	85	104	112
Q1	101	120	132
Q4	18	18	20
Q5	30	31	37
S	9	9	11
S2	9	9	11
S3	M8	M8	M8
T	28.3	28.3	35.3
t	28	28	35
t1	16	21.5	27
Weight (kg)	3	5.4	8.8

R...A轴装式安装
(可用于扭力臂安装)

R...A Shaft-mounted (Applicable
for torque arm mounting)

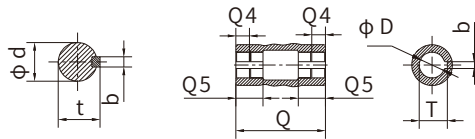
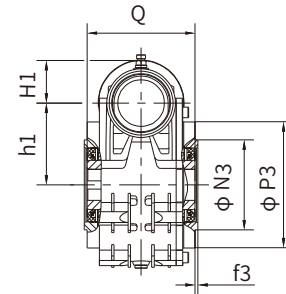
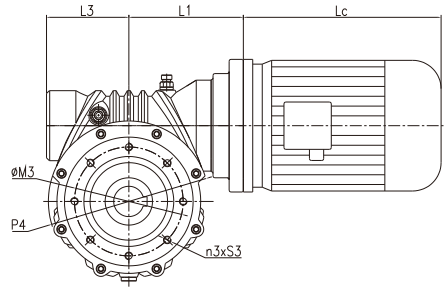
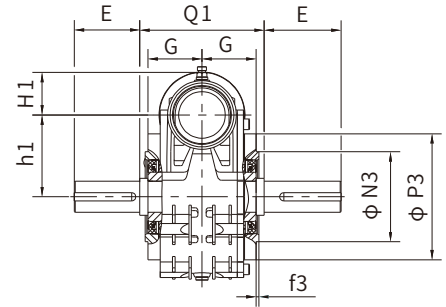
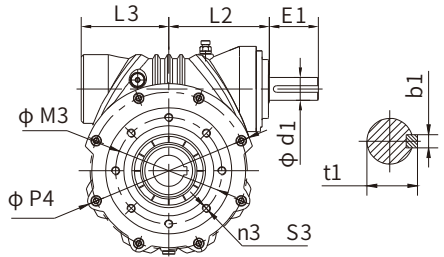

输出形式 :

Output Mode :

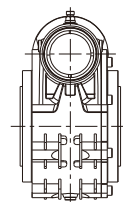
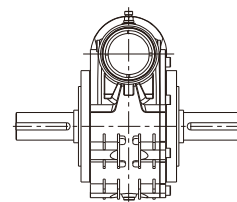
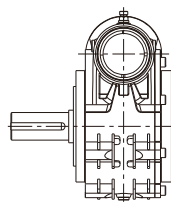
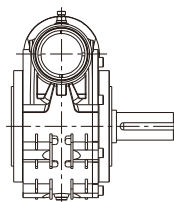

- ⚠ 1.要求带花键空心轴和锁紧盘空心轴输出时请来电咨询。
- 2.*重量不含电机和润滑油。
- 3.Lc见电机样本。

- ⚠ 1.For hollow shaft with spline hollowshaft or lockingplate hollow shaft,please consultus.
- 2.*Weight of motor and lubricationoil are notincluded.
- 3. Lc can be seen on motor sample.

7 外形尺寸图表:

7 Outline Dimension Diagram:

R.100~R.250

R...H底脚式安装
(可用于扭力臂安装)

R...HR...H foot-mounted
(Applicable for torque arm-mounting)

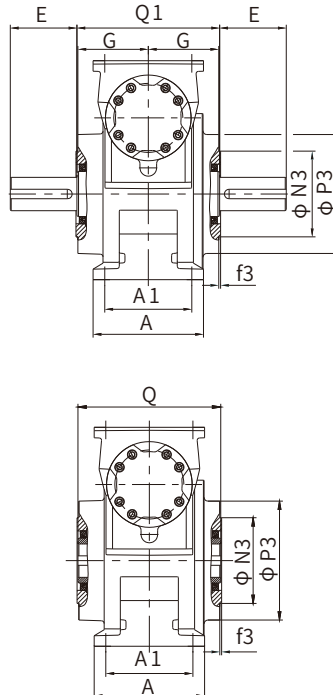
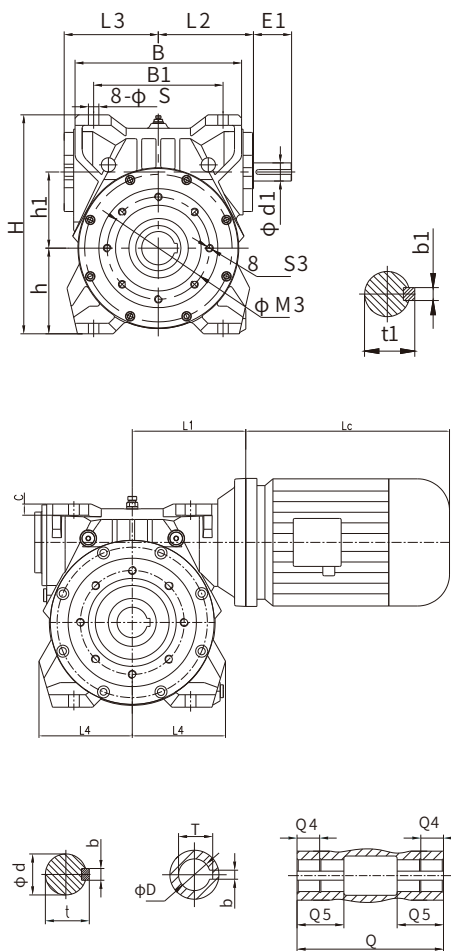

输出形式:

Output Mode :

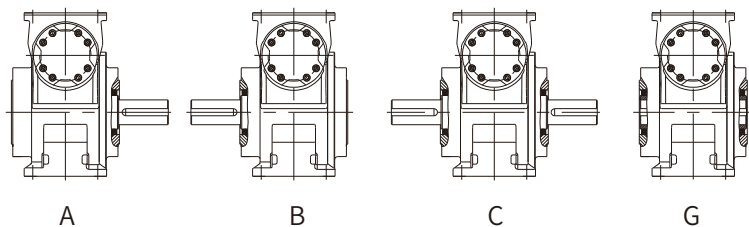

	R100	R125	R160	R200	R250
A	132	188	232	270	320
A1	105	162	183	214	250
B	214	258	350	441	552
B1	146	200	272	342	425
b	10	12	20	25	28
b1	8	8	10	14	18
C	14	16	22	30	35
C2	14	16	22	22	25
D	38H7	42H7	70H7	90H7	100H7
d	38K6	42k6	70m6	90m6	110m6
d1	28K6	28k6	38k6	48k6	60m6
E	80	110	140	170	210
E1	60	60	80	110	120
E2	94	120	181.5	211	261
F	100	136	191.5	216	256
f2	4	4	5	5	5
f3	3.5	3.5	4	5	5
G	66	97	148	173	203
G1	34	39	41.5	41	51
H	254	340	460	565	690
h	106	145	180	225	280
h1	100	125	160	200	250
L1	142	179	210	254	315
L2	123	165	200	248	307
L3	122	160.5	198	244	304
L4	115	143	192	240	295
M2	215	265	400	400	500
M3	130	165	215	265	300
N2	180h7	230h7	350h7	350h7	450h7
N3	110h7	130h7	180h7	230h7	250h7
n	4	4	8	8	8
P2	250	300	450	450	550
P3	152	190	250	300	340
Q	132	194	300	350	410
Q1	152	214	300	350	410
Q4	20	35	27	34	34
Q5	40	62	70	85	85
S	13.5	13.5	22	26	33
S2	13.5	13.5	17.5	17.5	17.5
S3	M10	M12	M16	M16	M16
T	41.3	45.3	74.9	95.4	106.4
t	41	45	74.5	95	106
t1	31	31	41	51.5	64
Weight (kg)	40	80	150	240	420

注:Lc见电机样本

Note:Lc can be seen on motorsample

7 外形尺寸图表:

7 Outline Dimension Diagram:

R.100~R.250

	R100	R125	R160	R200	R250
A	132	188	232	270	320
A1	105	162	183	214	250
B	214	258	350	441	552
B1	146	200	272	342	425
b	10	12	20	25	28
b1	8	8	10	14	18
C	14	16	22	30	35
C2	14	16	22	22	25
D	38H7	42H7	70H7	90H7	100H7
d	38K6	42k6	70m6	90m6	110m6
d1	28K6	28k6	38k6	48k6	60m6
E	80	110	140	170	210
E1	60	60	80	110	120
E2	94	120	181.5	211	261
F	100	136	191.5	216	256
f2	4	4	5	5	5
f3	3.5	3.5	4	5	5
G	66	97	148	173	203
G1	34	39	41.5	41	51
H	254	340	460	565	690
h	106	145	180	225	280
h1	100	125	160	200	250
L1	142	179	210	254	315
L2	123	165	200	248	307
L3	122	160.5	198	244	304
L4	115	143	192	240	295
M2	215	265	400	400	500
M3	130	165	215	265	300
N2	180h7	230h7	350h7	350h7	450h7
N3	110h7	130h7	180h7	230h7	250h7
n	4	4	8	8	8
P2	250	300	450	450	550
P3	152	190	250	300	340
Q	132	194	300	350	410
Q1	152	214	300	350	410
Q4	20	35	27	34	34
Q5	40	62	70	85	85
S	13.5	13.5	22	26	33
S2	13.5	13.5	17.5	17.5	17.5
S3	M10	M12	M16	M16	M16
T	41.3	45.3	74.9	95.4	106.4
t	41	45	74.5	95	106
t1	31	31	41	51.5	64
Weight (kg)	40	80	150	240	420

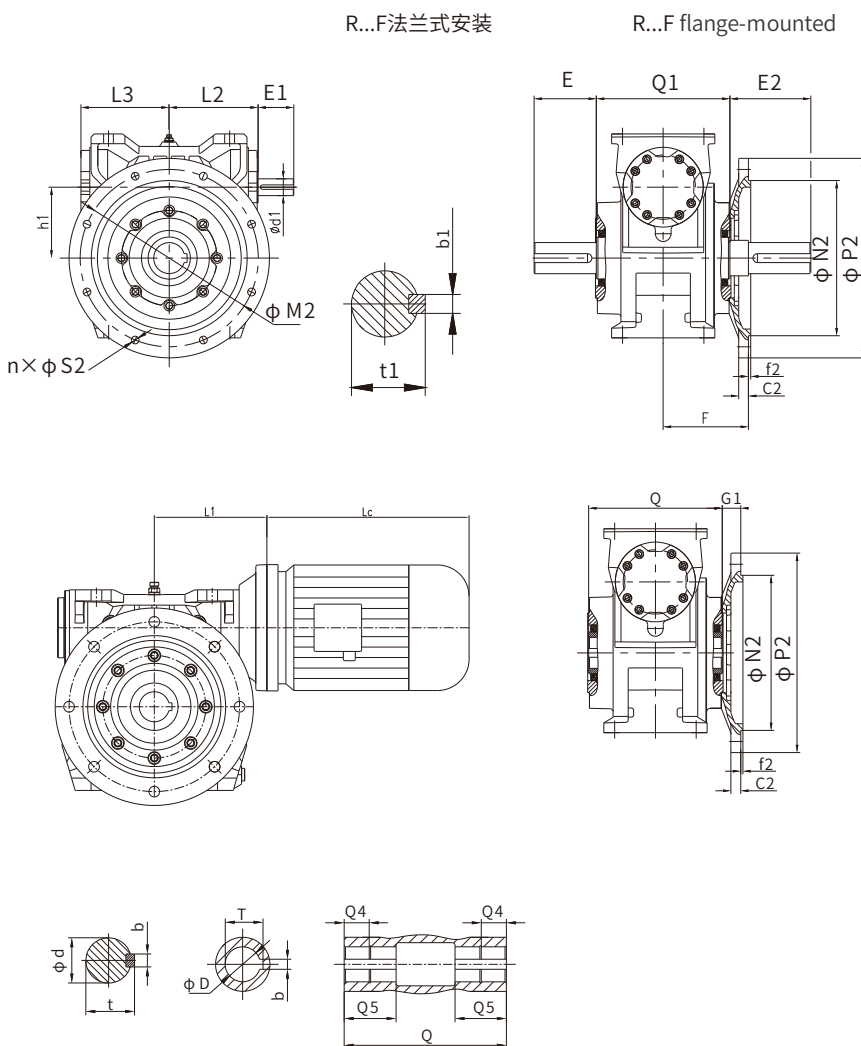

输出形式:

Output Mode:

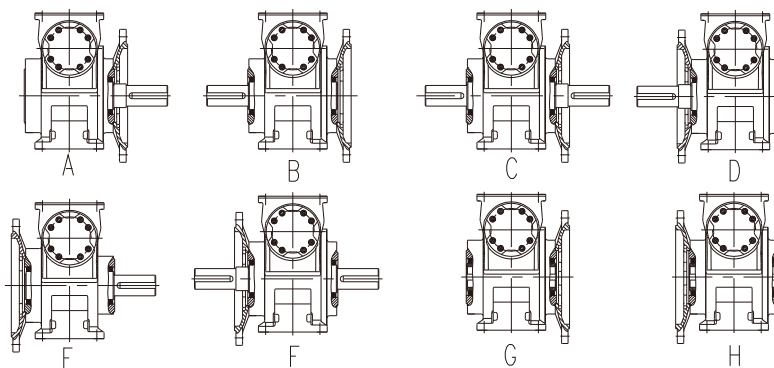

注:Lc见电机样本

Note:Lc can be seen on motorsample

8 同向轴输出代号为N: 8 Output Code of Homodromous Shaft is N:

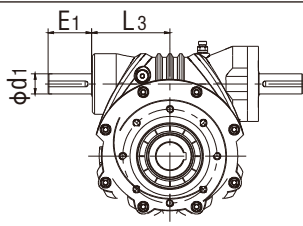

	R050	R063	R080	R100	R125	R160	R200	R250
d1	14k6	19k6	24k6	28k6	28k6	38k6	48k6	60m6
E1	30	40	50	60	60	80	110	120
L3	62	75	89	123	165	200	248	307

9 输入法兰与轴孔尺寸: 9 Dimensions of Input Flange and Shaft Bore:

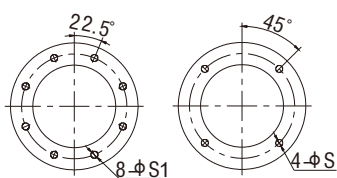

P > 400

P ≤ 400

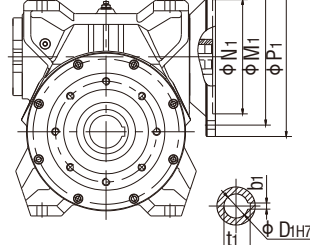
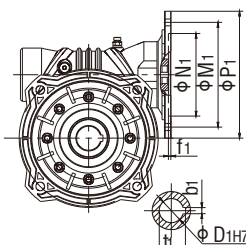
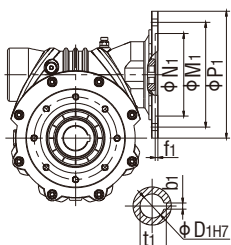

R050 - R080

R100 - R250

Size	D1 蜗杆标准孔径 D1 Standard bore diameter of D1 worm rod							法兰尺寸 Flange dimensions							
	IN							b1	t1	N1	M1	P1	S1	f1	代号
	7	10	15	20	30	45	60								
R050	19	19	19	19	/	/	/	6	21.8	130	165	200	Φ 11	4	AF80
	14	14	14	14	14	14	14	5	16.8	110	130	160	Φ 9	4	AF71
	11	11	11	11	11	11	11	4	12.8	95	115	140	Φ 9	3	AF63
R063	24	24	24	24	/	/	/	8	27.3	130	165	200	Φ 11	5	AF90
	/	19	19	19	19	/	/	6	21.8						AF80
	/	/	/	/	14	14	14	5	16.8	110	130	160	Φ 9	4	AF71
	/	/	/	/	11	11	11	4	12.8	95	115	140	Φ 9	3	AF63
R080	28	28	28	28	28	/	/	8	31.3	180	215	250	Φ 13.5	4.5	AF100
	/	24	24	24	24	24	/	8	27.3	130	165	200	Φ 11	5	AF90
	/	19	19	19	19	19	19	6	21.8						AF80
	/	/	/	/	/	14	14	5	16.8	110	130	160	Φ 9	4	AF71
R100	28	28	28	28	28	/	/	8	31.3	180	215	250	Φ 13.5	4.5	AF100
	24	24	24	24	24	24	24	8	27.3	130	165	200	Φ 11	5	AF90
	/	/	/	19	19	19	19	6	21.8						AF80
R125	38	38	38	38	38	38	/	10	41.3	230	265	300	Φ 13.5	4.5	AF132
	28	28	28	28	28	28	28	8	31.3	180	215	250	Φ 13.5	4.5	AF100
	/	/	/	/	/	24	24	8	27.3	130	165	200	Φ 9	4	AF90
R160	/	/	42	/	42	/	/	12	45.3	250	300	350	M16	5	AF160
	/	/	38	/	38	38	38	10	41.3	230	265	300	M12	4.5	AF132
	/	/	/	/	28	28	28	8	31.3	180	215	250	Φ 13.5	4.5	AF100
R200	/	/	48	/	/	/	/	14	51.8	250	300	350	M16	5.5	AF180
	/	/	42	/	42	42	/	12	45.3						AF160
	/	/	/	/	38	38	/	10	41.3	230	265	300	M12	4.5	AF132
R250	/	/	55	/	/	/	/	16	59.3	300	350	400	M16	5.5	AF200
	/	/	48	/	48	48	/	14	51.8	250	300	350	M16	5.5	AF180
	/	/	/	/	42	42	/	12	45.3	180	215	250	Φ 13.5	4.5	AF160

10 组合型:

10.1 R../CR..组合型:

10 Combined type:

10.1 R../CR..Combined type:

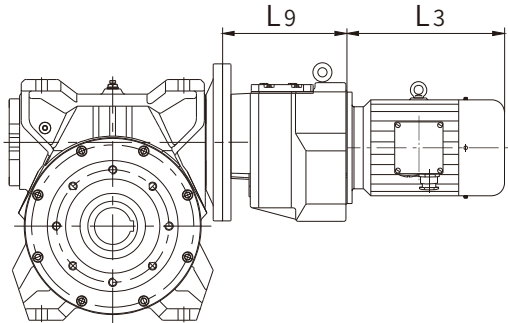
<p>R../CR</p> 	型号 型号 type	L9
	R125/CR47	182
	R160/CR67	210
	R200/CR77	226
	R250/CR87	281

10.2 组合型尺寸及
布置形式:

10.2 Dimensions and arrangement
of Combined -type:

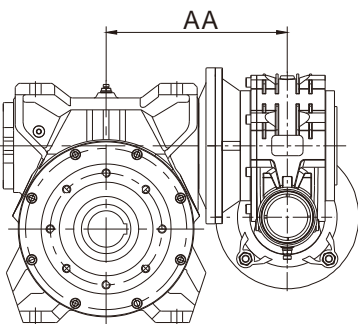
								
	R050/R050	R063/R050	R080/R050	R100/R050	R125/R063	R160/R080	R200/R100	R250/R125
AA	148	155	180	200	245	310	360	460

组合布置形式代号

Combine-type Designs

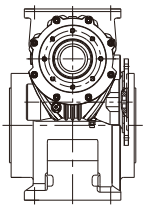
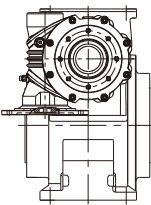
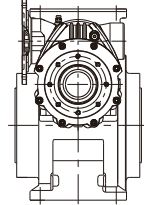
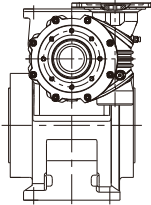
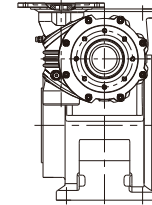
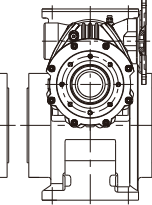
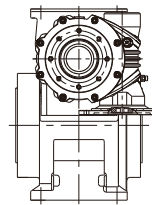
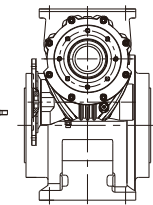
							
ZR01	ZR02	ZR03	ZR04	ZR05	ZR06	ZR07	ZR08

11 附件:

11 Attachment:

11.1 扭力臂 (代号T43/T44) 11.1 Torque arm (code T43/T44)

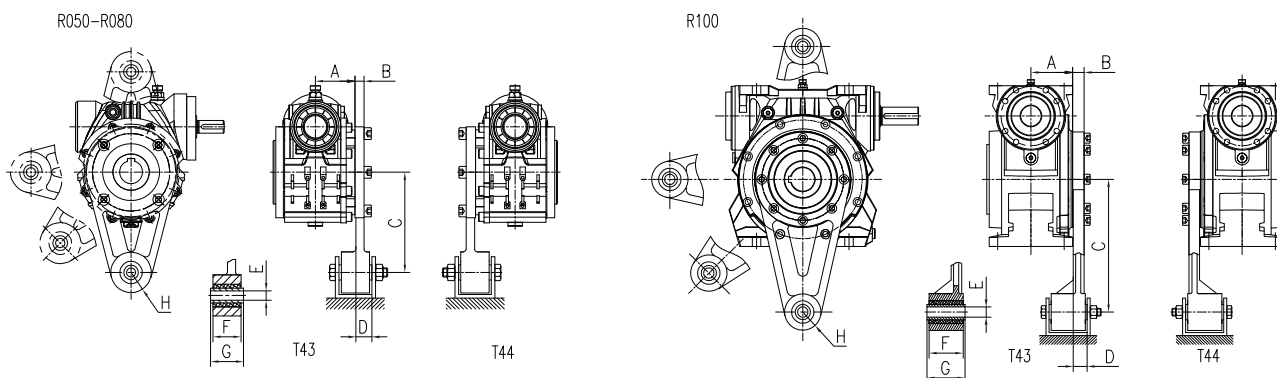

规格 Size	R050	R063	R080	R100
A	43.5	53	57	66
B	10	10	15	18
C	110	125	155	210
D	18.5	18.5	20.5	22
E	10.4	10.4	10.4	16.4
F	31	31	31	54
G	36	36	36	60
H	22.5	22.5	22.5	29

11.2 空心轴附件 (代号U09)

11.2 Attachment of hollow shaft (Code U09)

规格 Size	S0	L0
	R050	18.8
R063	18.8	M10x25
R080	18.8	M12X25
R100	18.5	M12X25
R125	24.2	M16X40
R160	42.5	M20X60
R200	54	M24X70
R250	51	M24X70

11.3 润滑油

11.3 Lubrication oil

单位: L

单位: L

Unit:(L)

规格 size 安装 方位 mounting position	R050	R063	R080	R100	R125	R160	R200	R250
D1	0.25	0.5	0.75	1	8	15	30	55
D2/D4	0.3	0.5	0.75	1	10	20	35	60
D5/D6	0.25	0.5	0.75	1	3.5	6	10	17.5
D3	0.25	0.5	0.75	1	6	10	20	35

⚠注:产品使用环境温度 -20°C~+40°C时,

1.R050~R080系列出厂已加入000#极压锂基润滑脂,附件代号为UV00;

2.R100~R250推荐采用蜗轮蜗杆润滑油,粘度牌号:ISO VG680,附件代号为UV68。

(1) 当使用环境温度低于-10°C时必须使用合成油;

(2) 为确保产品的使用寿命,推荐使用合成油;

(3) 使用环境温度超出上述范围时, 请向BONENG咨询。

⚠Note: when ambient temperature is-20°C-40°C.

1.R050-R080Series have been filled with 000# pole pressure lithium lubrication grease when delivered,the code is UV00;

2.R100-R250 are recommended to apply worm rod lubrication ,oil viscosity brand number:ISO VG680, accessory code UV68.

(1) When ambient temperature is lower than -10°C,synthetic oil should be used;

(2) To ensure lifespan of the product,we recommend synthetic oil;

(3) When ambient temperature exceeds the above range,please consult BONENG.

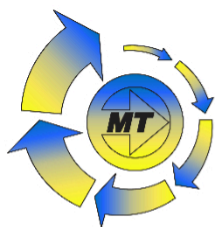

Distributors for Australia & New Zealand
MOTION TECHNOLOGIES PTY LIMITED



24/22-30 Northumberland Road
Caringbah NSW 2229 Australia
Phone: (02) 9524 4782

sales@motiontech.com.au
www.motiontech.com.au

© 08/08/2024

BONENG