

MOONS'
moving in better ways

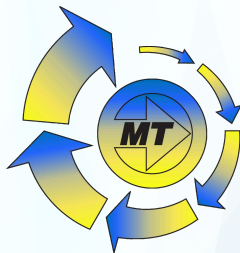

INTEGRATED STEP-SERVO

- Multi-axis field bus control
- Intelligent built-in controller
- Compact all-in-one solution
- Efficient, smooth, accurate, fast
- Enhanced motor, optimized design



TXM



TSM



Closed
Loop
CE RoHS
Compliant

www.motiontech.com.au

The Step-Servo is an innovative revolution for the world of stepper motor, it enhances the stepper motors with servo technology to create a product with exceptional feature and broad capability.

Multi-functional Capability

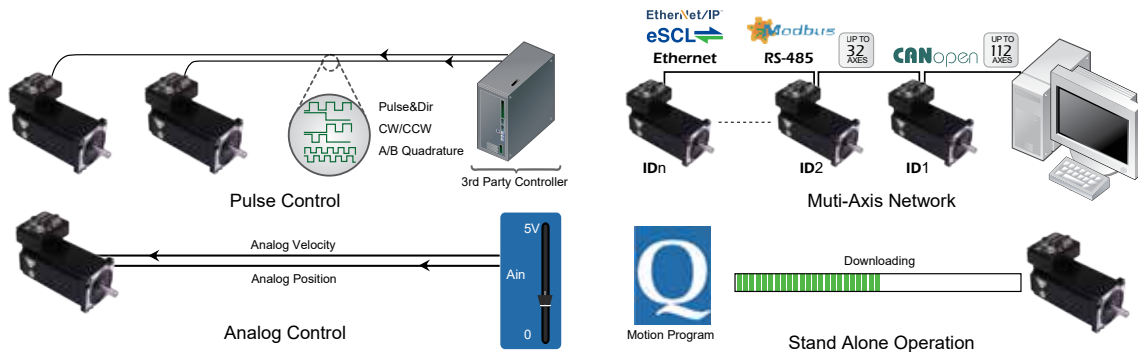

Closed Loop

- Very tight position and velocity control for the most demanding applications.
- Robust servo loops that tolerate wide fluctuation in load inertia and frictional loading.
- The TSM17/23/24/34 achieve precise positioning to within ± 1 count (0.018°) using a high resolution (20000 counts/rev) encoder.
- The TSM11 achieves precise positioning to within ± 1 count (0.2°) using a high resolution (4096 counts/rev) encoder.
- For TXM24/34, precise positioning to within ± 1 count (0.018°) using high resolution (20000 counts/rev) encoder.

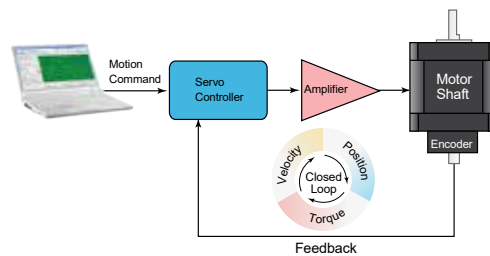

Low Heating/High Efficiency

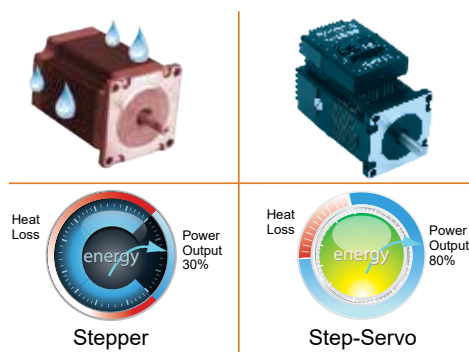

- Uses only the current required by the application, generating minimum heat output.
- When stand-still, current can reach nearly zero for extremely low heat output.
- Being able to use almost 100% of torque, allows for more efficient and compact motor usage.

Smooth & Accurate

- Space vector current control with 5000 line high resolution encoder, gives smooth and quiet operation, especially at low speeds.
 - A feature never found with traditional stepping motors
- High stiffness due to the nature of the stepping motor combined with the highly responsive servo control
 - Accurate position control both while running and static positioning

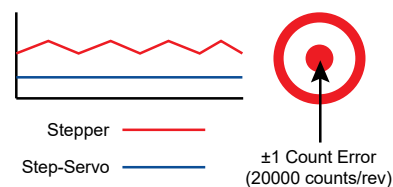

Fast Response

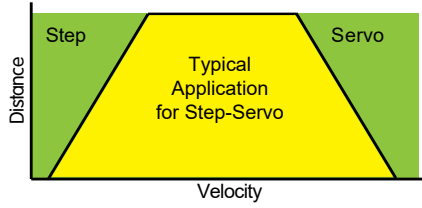

- When performing fast point-to-point moves, the high torque output and advanced servo control provides a very responsive system far exceeding what can be done with a conventional stepper system.

High Torque

- Because the operates in full servo mode, all the available torque of the motor can be used.
- The motor can provide as much as 50% more torque in many applications. High torque capability often eliminates the need for gear reduction.
- Boost torque capability can provide as much as 50% more torque for short, quick moves.

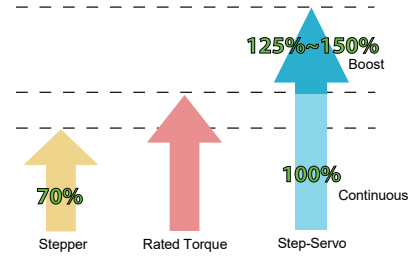

Easy Tuning

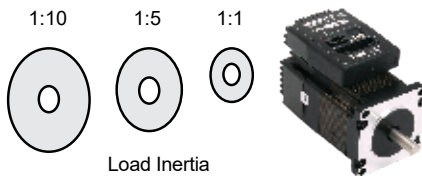

- Pre-defined tuning parameters quickly allow maximum control performance and stability.
- A selection list provides an easy method to achieve the desired level of control.
- In most cases NO extra manual tuning is required.

TSM Series Integrated Step-Servo Motor



■ TSM Series Features

- Up to 8 digital inputs, 4 digital outputs and 1 analog input for S/Q/C types (TSM17/23/24/34 only)
- A/B/Z differential encoder signal output supported for P type (TSM17/23/24/34 only)
- Automatic load inertia detection
- On board daisy chain connection for field bus control (RS-485, Modbus/RTU, CANopen, TSM17/23/24/34 only)
- On board daisy chain over Ethernet on TSM34 only
- Multiple homing features for S/Q types
- Software limit for S/Q types
- Auxiliary power input for Keep Alive function (TSM34 only)

■ Numbering System

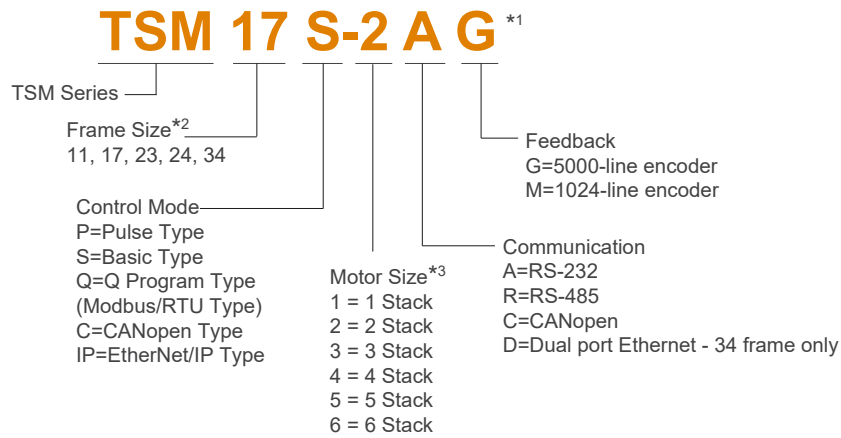

Note:

*1 See ordering information table below for available model.

*2 Refers to the size of the motor mounting surface: 11 (28mm), 17 (42mm), 23 (56mm), 24 (60mm), 34 (86mm).

*3 Please refer to the mechanical dimension drawing of the corresponding model for the specific length.

■ Ordering Information

Model	Torque	Control	I/O(*)	RS-232	RS-485/422	Modbus/RTU	CANopen	Ethernet	Ethernet/IP
TSM11S-1RM	0.065N·m	S	4DI, 2DO		√				
TSM11S-2RM	0.08N·m				√				
TSM11S-3RM	0.125N·m				√				
TSM11Q-1RM	0.065N·m	Q				√			
TSM11Q-2RM	0.08N·m					√			
TSM11Q-3RM	0.125N·m					√	√		
TSM17P-1AG	0.3N·m	P	4DI,3DO,EO	√					
TSM17S-1AG		S	8DI,4DO,1AI	√					
TSM17S-1RG						√			
TSM17Q-1AG		Q	8DI,4DO,1AI	√		√			
TSM17Q-1RG						√	√		
TSM17C-1CG			C	8DI,4DO,1AI	√			√	
TSM17P-2AG	0.5N·m	P	4DI,3DO,EO	√					
TSM17S-2AG		S	8DI,4DO,1AI	√					
TSM17S-2RG						√			
TSM17Q-2AG		Q	8DI,4DO,1AI	√		√			
TSM17Q-2RG						√	√		
TSM17C-2CG			C	8DI,4DO,1AI	√			√	
TSM17P-3AG	0.6N·m	P	4DI,3DO,EO	√					
TSM17S-3AG		S	8DI,4DO,1AI	√					
TSM17S-3RG						√			
TSM17Q-3AG		Q	8DI,4DO,1AI	√		√			
TSM17Q-3RG						√	√		
TSM17C-3CG			C	8DI,4DO,1AI	√			√	
TSM17P-4AG	0.75N·m	P	4DI,3DO,EO	√					
TSM17S-4AG		S	8DI,4DO,1AI	√					
TSM17S-4RG						√			
TSM17Q-4AG		Q	8DI,4DO,1AI	√		√			
TSM17Q-4RG						√	√		
TSM17C-4CG			C	8DI,4DO,1AI	√			√	

Model	Torque	Control	I/O(*)	RS-232	RS-485/422	Modbus/RTU	CANopen	Ethernet	Ethernet/IP
TSM23P-2AG	1.0N·m	P	4DI,3DO,EO	√					
TSM23S-2AG		S	8DI,4DO,1AI,EO	√					
TSM23S-2RG					√				
TSM23Q-2AG		Q	8DI,4DO,1AI,EO	√		√			
TSM23Q-2RG					√	√			
TSM23C-2CG		C	8DI,4DO,1AI	√			√		
TSM23P-3AG	1.5N·m	P	4DI,3DO,EO	√					
TSM23S-3AG		S	8DI,4DO,1AI,EO	√					
TSM23S-3RG						√			
TSM23Q-3AG		Q	8DI,4DO,1AI,EO	√		√			
TSM23Q-3RG						√	√		
TSM23C-3CG		C	8DI,4DO,1AI	√			√		
TSM23P-4AG	2.5N·m	P	4DI,3DO,EO	√					
TSM23S-4AG		S	8DI,4DO,1AI,EO	√					
TSM23S-4RG							√		
TSM23Q-4AG		Q	8DI,4DO,1AI,EO	√		√			
TSM23Q-4RG							√	√	
TSM23C-4CG		C	8DI,4DO,1AI	√			√		
TSM24P-3AG	2.5N·m	P	4DI,3DO,EO	√					
TSM24S-3AG		S	8DI,4DO,1AI,EO	√					
TSM24S-3RG							√		
TSM24Q-3AG		Q	8DI,4DO,1AI,EO	√		√			
TSM24Q-3RG							√	√	
TSM24C-3CG		C	8DI,4DO,1AI	√			√		
TSM34P-1AG	2.7N.m	P	4DI,3DO,EO	√					
TSM34Q-1AG		Q	8DI,4DO,1AI,EO	√		√			
TSM34Q-1RG							√	√	
TSM34Q-1DG		C	8DI,4DO,1AI,EO					√	
TSM34C-1CG					√			√	
TSM34IP-1DG		IP						√	√
TSM34P-3AG	5.2N.m	P	4DI,3DO,EO	√					
TSM34Q-3AG		Q	8DI,4DO,1AI,EO	√		√			
TSM34Q-3RG							√	√	
TSM34Q-3DG		C	8DI,4DO,1AI,EO					√	
TSM34C-3CG					√			√	
TSM34IP-3DG		IP						√	√
TSM34P-5AG	6.7N.m	P	4DI,3DO,EO	√					
TSM34Q-5AG		Q	8DI,4DO,1AI,EO	√		√			
TSM34Q-5RG							√	√	
TSM34Q-5DG		C	8DI,4DO,1AI,EO					√	
TSM34C-5CG					√			√	
TSM34IP-5DG		IP						√	√
TSM34P-6AG	8.2N.m	P	4DI,3DO,EO	√					
TSM34Q-6AG		Q	8DI,4DO,1AI,EO	√		√			
TSM34Q-6RG							√	√	
TSM34Q-6DG		C	8DI,4DO,1AI,EO					√	
TSM34C-6CG					√			√	
TSM34IP-6DG		IP						√	√

* DI: Digital Input; DO: Digital Output; EO: Encoder Output; AI: Analog Input

Features

Efficient
Integrated
TSM

IP65
Integrated
TXM

Appendix

System configuration

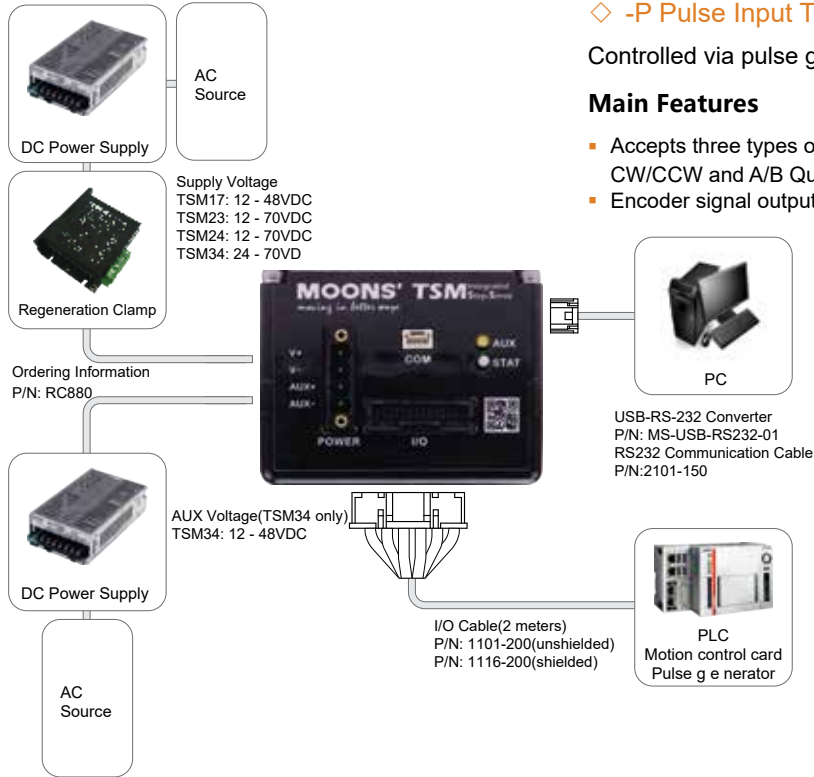

◇ -P Pulse Input Type (TSM17/23/24/34 only)

Controlled via pulse generator

Main Features

- Accepts three types of pulse signal input: Pulse/Direction, CW/CCW and A/B Quadrature
- Encoder signal output, A/B/Z differential

◇ -S Basic Type w/Serial Communication (TSM11/17/23/24 only)

Controlled via pulse signals, analog signals or MOONS' SCL streaming serial commands

Main Features

- Pulse control
- Analog control
- Host real time control using SCL via RS-232/RS-485
- Up to 32 axes per channel for RS-485

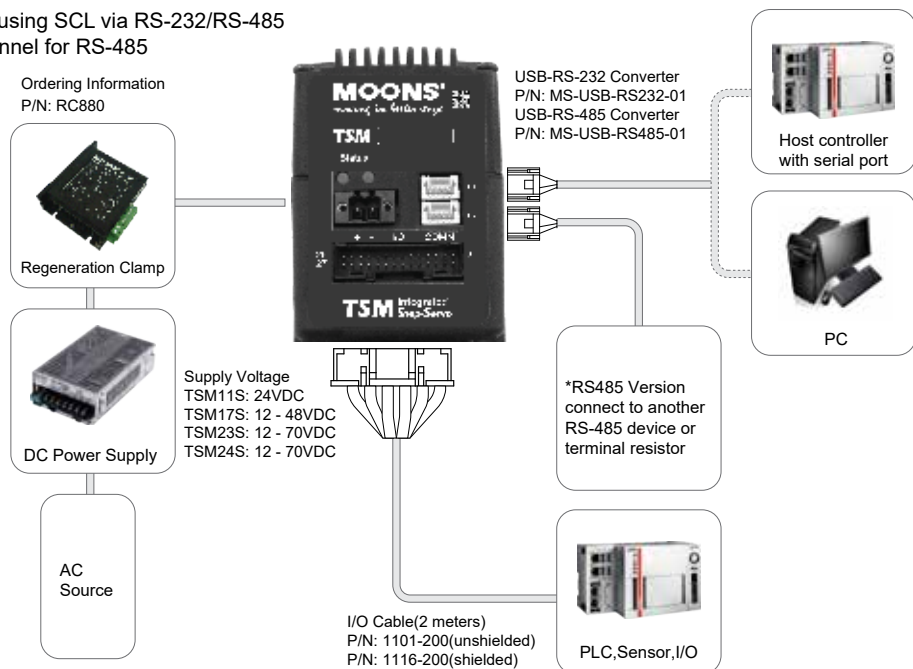

◇ -Q Built-in Programmable Motion Controller (Includes Modbus/RTU)

Runs stand-alone with sophisticated and functional programs. Commands for controlling motion, inputs & outputs, drive configuration and status, as well as math operations, register manipulation, and multi-tasking.

Main Features

- Stand-alone operation plus serial host control
- Math operations
- Register manipulation
- Multi-tasking
- Includes all features of S type
- Modbus/RTU network, up to 32 axes per channel
- Dual port Ethernet communication, eSCL network (TSM34 only)

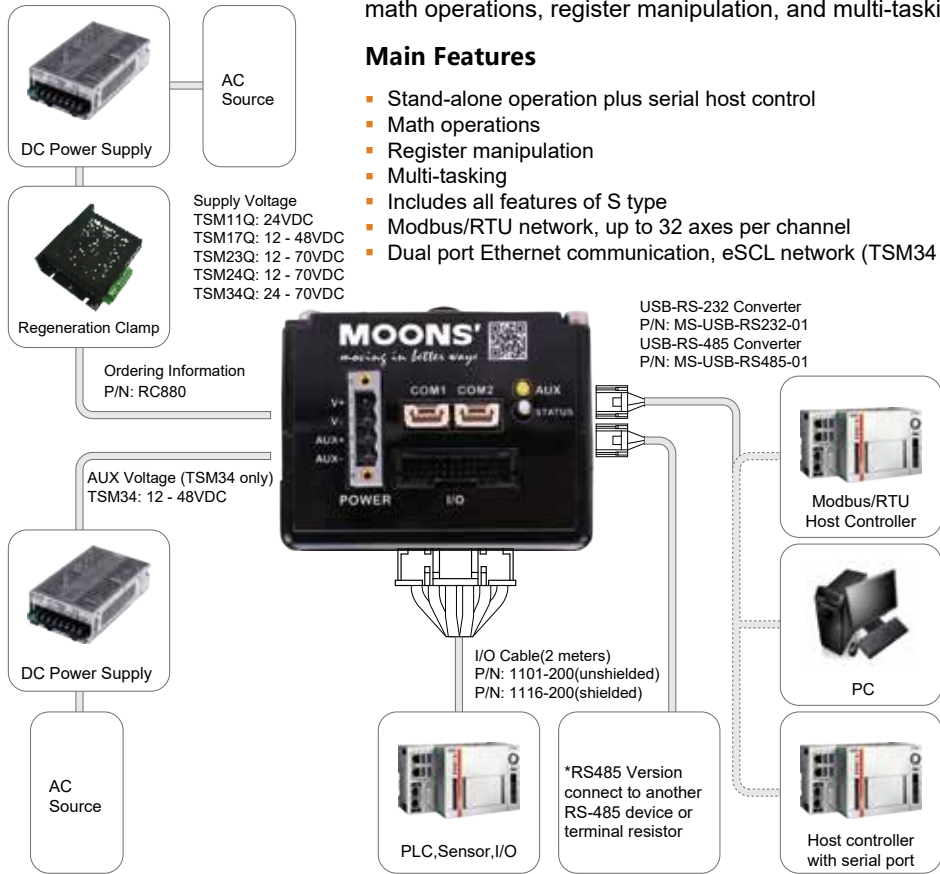

◇ -C CANOpen Type (TSM17/23/24/34 only)

Operates on a CANOpen communication network and conforms to CiA301 and CiA402. Supports running stored Q programs via MOONS'-specific CANOpen objects.

Main Features

- CANOpen network
- Up to 112 axes per channel
- Objects for Q programming

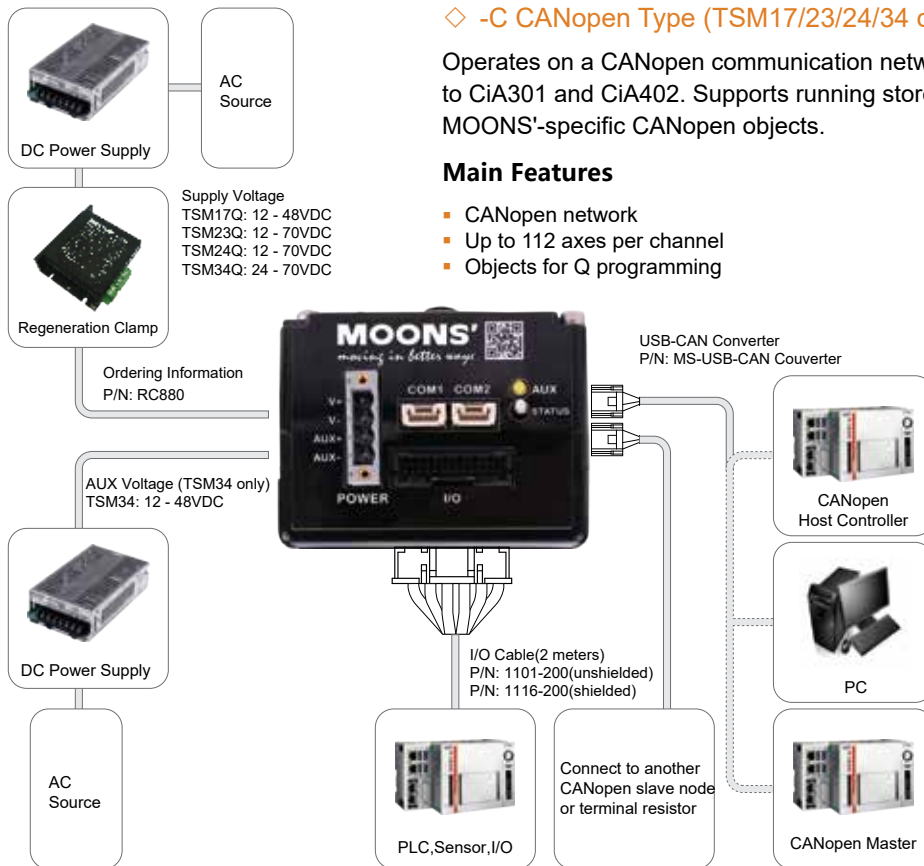

◇ -IP EtherNet/IP Type (TSM34 only)

Operates on a EtherNet/IP communication network. Supports running stored Q programs via MOONS'-specific EtherNet/IP objects.

Main Features

- EtherNet/IP network
- Objects for Q programming
- SCL

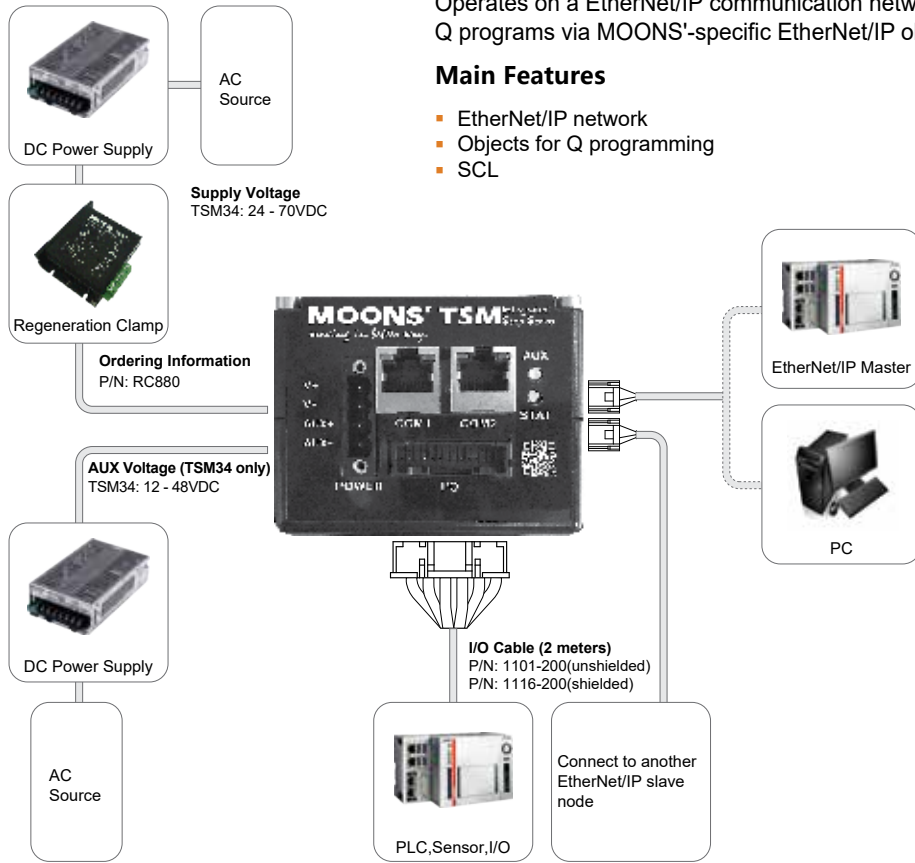

Specifications

◇ Frame size 28mm

Model	Basic type	TSM11S-1RM	TSM11S-2RM	TSM11S-3RM
	Q program type (Includes Modbus/RTU)	TSM11Q-1RM	TSM11Q-2RM	TSM11Q-3RM
Torque	N•m	0.065	0.08	0.125
Rotor Inertia	g•cm ²	9	12	18
Supply Voltage	VDC	24		
Encoder Resolution	counts/rev	4096	4096	4096
Maximum Speed	RPM	3600	3600	3600
Mass	g	118	168	218

◇ Torque Curves

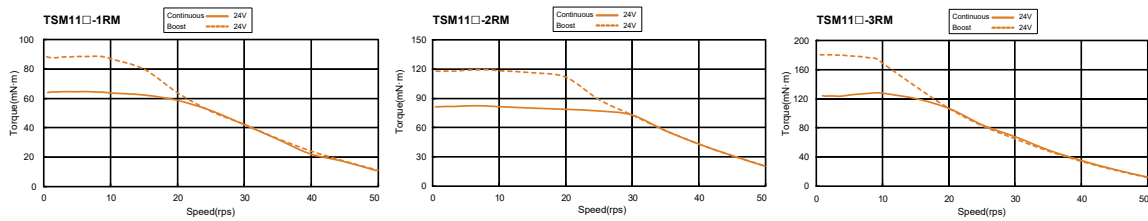

◇ Electrical Specifications

	Basic type TSM11S-■RM	Q program type TSM11Q-■RM
Control Command	Pulse input SCL	Pulse input SCL Q Program Modbus/RTU
Communication	RS-485 four-wire	
Protocol	SCL	Modbus/RTU or SCL
Pulse signal type	Pulse/Direction, CW/CCW Pulse, A/B Quadrature	Pulse/Direction, CW/CCW Pulse, A/B Quadrature
Maximum Input Pulse Frequency	2MHz, Minimum Pulse Width=250ns	2MHz, Minimum Pulse Width=250ns
Digital Inputs	4	4
Digital Outputs	2	2
Analog Inputs	-	-
Encoder Output	-	-
Digital Input	5-24VDC	
Digital Output	30VDC/100mA	
Supply Voltage	24VDC rated, accepts 15-30VDC in min/max.	
Protection	Over-voltage, under-voltage, over-temp, motor/wiring shorts (phase-to-phase, phase-to-ground)	

Enter motor length 1, 2, 3 in the box (■) within the model name

◇ Frame size 42mm

Model	Pulse input type	TSM17P-1AG	TSM17P-2AG	TSM17P-3AG	TSM17P-4AG
	Basic type	TSM17S-1□G	TSM17S-2□G	TSM17S-3□G	TSM17S-4□G
	Q program type (Includes Modbus/RTU)	TSM17Q-1□G	TSM17Q-2□G	TSM17Q-3□G	TSM17Q-4□G
	CANopen type	TSM17C-1CG	TSM17C-2CG	TSM17C-3CG	TSM17C-4CG
Torque	N•m	0.3	0.5	0.6	0.75
Rotor Inertia	g•cm ²	38	57	82	123
Supply Voltage	VDC	12-48			
Encoder Resolution	counts/rev	20000	20000	20000	20000
Maximum Speed	RPM	3600	3600	3600	3600
Mass	g	390	440	520	760

Enter A (RS-232) or R (RS-485) in the box (□) within the model name

◇ Torque Curves

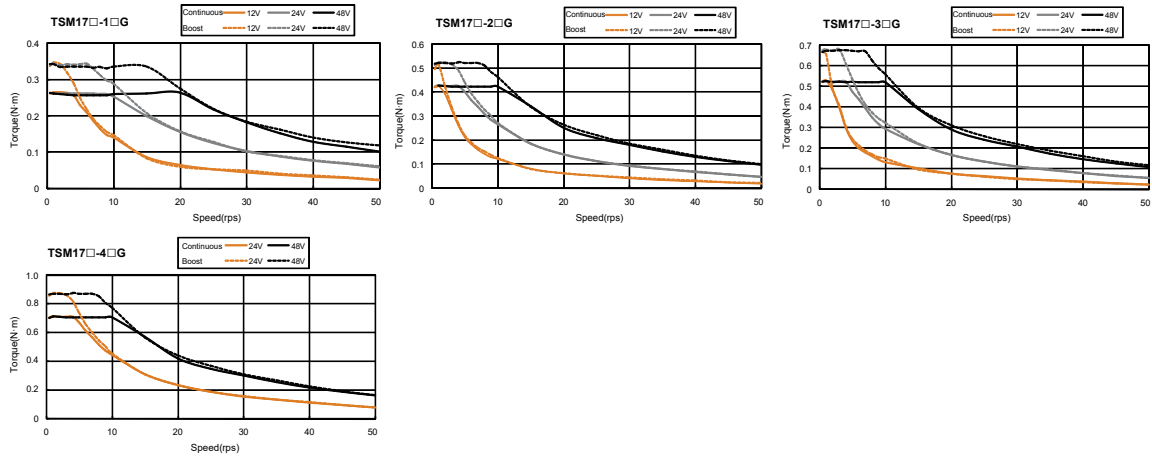

◇ Electrical Specifications

	Pulse input type TSM17P-■AG	Basic type TSM17S-■□G	Q program type TSM17Q-■□G	CANopen type TSM17C-■CG
Control Command	Pulse input	Pulse input Analog signal SCL	Pulse input Analog signal SCL Q program Modbus/RTU	Q program CANopen
Communication	RS-232	RS-232 or RS-485	RS-232 or RS-485	RS-232&CANopen
Protocol	-	SCL	Modbus/RTU or SCL	CANopen
Pulse signal type	Pulse/Direction CW/CCW Pulse A/B Quadrature	Pulse/Direction CW/CCW Pulse A/B Quadrature	Pulse/Direction CW/CCW Pulse A/B Quadrature	-
Maximum Input Pulse Frequency	2MHz, Min. Pulse Width=250ns	2MHz, Min. Pulse Width=250ns	2MHz, Min. Pulse Width=250ns	-
Digital Inputs	4	8	8	8
Digital Outputs	3	4	4	4
Analog Inputs	-	1	1	1
Encoder Output	20,000 counts/rev A/B/Z differential	-	-	-
Digital Input	Optically isolated, 5-24VDC			
Digital Output	Optically isolated, 30VDC/100mA			
Analog Input	AIN referenced to GND, Range 0-5VDC, Resolution: 12bits			
Supply Voltage	12-48VDC			
Protection	Over-voltage, under-voltage, over-temp, motor/wiring shorts (phase-to-phase, phase-to-ground)			

Enter motor length 1, 2, 3, 4 in the box (■) within the model name
Enter A (RS-232) or R (RS-485) in the box (□) within the model name

◇ Frame size 56mm, 60mm

Model	Pulse input type	TSM23P-2AG	TSM23P-3AG	TSM23P-4AG	TSM24P-3AG
	Basic type	TSM23S-2□G	TSM23S-3□G	TSM23S-4□G	TSM24S-3□G
	Q program type (Includes Modbus/RTU)	TSM23Q-2□G	TSM23Q-3□G	TSM23Q-4□G	TSM24Q-3□G
	CANopen type	TSM23C-2CG	TSM23C-3CG	TSM23C-4CG	TSM24C-3CG
Torque	N•m	0.9	1.5	2.5	2.5
Rotor Inertia	g•cm ²	260	460	365	900
Supply Voltage	VDC	12-70			
Encoder Resolution	counts/rev	20000	20000	20000	20000
Maximum Speed	RPM	3600	3600	3600	3600
Mass	g	850	1250	1090	1650

Enter A (RS-232) or R (RS-485) in the box (□) within the model name

◇ Torque Curves

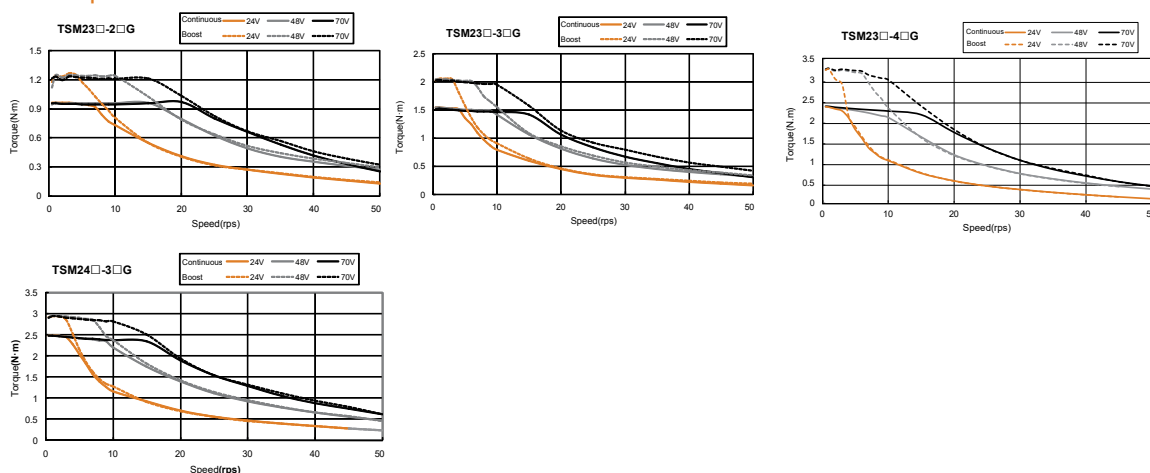

◇ Electrical Specifications

	Pulse input type TSM2◇P-■AG	Basic type TSM2◇S-■□G	Q program type TSM2◇Q-■□G	CANopen type TSM2◇C-□CG
Control Command	Pulse input	Pulse input Analog signal SCL	Pulse input Analog signal SCL Q program Modbus/RTU	Q program CANopen
Communication	RS-232	RS-232 or RS-485	RS-232 or RS-485	RS-232&CANopen
Protocol	-	SCL	Modbus/RTU or SCL	CANopen
Pulse signal type	Pulse/Direction CW/CCW Pulse A/B Quadrature	Pulse/Direction CW/CCW Pulse A/B Quadrature	Pulse/Direction CW/CCW Pulse A/B Quadrature	-
Maximum Input Pulse Frequency	2MHz, Min. Pulse Width=250ns	2MHz, Min. Pulse Width=250ns	2MHz, Min. Pulse Width=250ns	-
Digital Inputs	4	8	8	8
Digital Outputs	3	4	4	4
Analog Inputs	-	1	1	1
Encoder Output	20,000 counts/rev A/B/Z differential	20,000 counts/rev A/B/Z differential	20,000 counts/rev A/B/Z differential	-
Digital Input	Optically isolated, 5-24VDC			
Digital Output	Optically isolated, 30VDC/100mA			
Analog Input	AIN referenced to GND, Range 0-5VDC, Resolution: 12bits			
Supply Voltage	12-70VDC			
Protection	Over-voltage, under-voltage, over-temp, motor/wiring shorts (phase-to-phase, phase-to-ground)			

Enter frame size 3 (56mm) or 4 (60mm) in the box (◇) within the model name

Enter motor length 2, 3, 4 in the box (■) within the model name

Enter A (RS-232) or R (RS-485) in the box (□) within the model name

◇ Frame size 86mm

Model	Pulse input type	TSM34P-1AG	TSM34P-3AG	TSM34P-5AG	TSM34P-6AG
	Q program type (Includes Modbus/RTU, Ethernet type)	TSM34Q-1□G	TSM34Q-3□G	TSM34Q-5□G	TSM34Q-6□G
	CANopen type	TSM34C-1CG	TSM34C-3CG	TSM34C-5CG	TSM34C-6CG
Torque	N·m	2.7	5.2	6.7	8.2
Rotor Inertia	g·cm ²	915	1480	2200	3660
Supply Voltage	VDC	24-70			
Encoder Resolution	counts/rev	20000	20000	20000	20000
Maximum Speed	RPM	3600	3600	3600	3600
Mass	g	4600	6800	9000	11400

Enter A (RS-232), R (RS-485) or D (Dual port Ethernet) in the box (□) within the model name

◇ Torque Curves

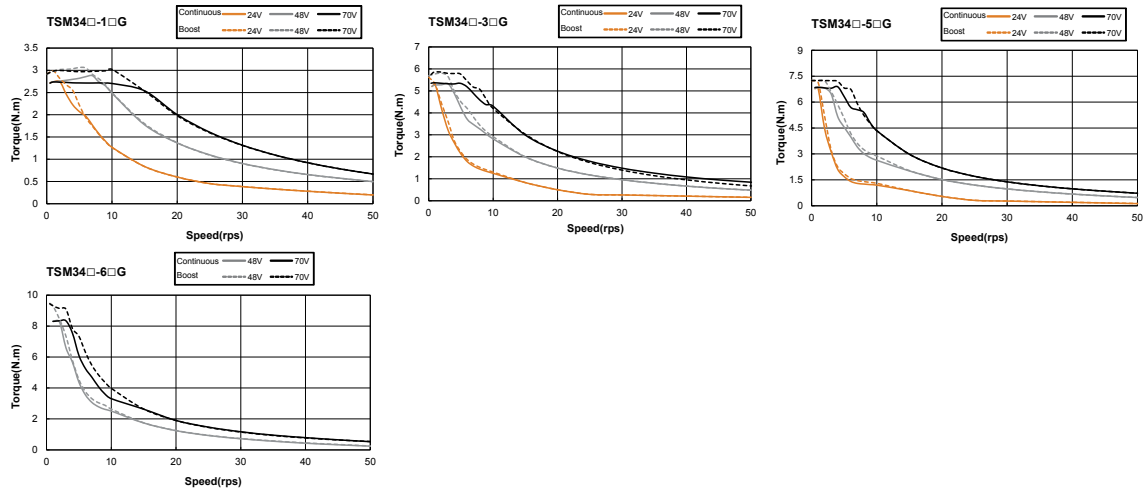

◇ Electrical Specifications

	Pulse input type TSM34P-■AG	Q program type TSM34Q-■□G	CANopen type TSM34C-■CG
Control Command	Pulse input	Pulse input Analog signal SCL or eSCL Q program Modbus/RTU	Q program CANopen
Communication	RS-232	RS-232 or RS-485 or Ethernet	RS-232&CANopen
Protocol	-	Modbus/RTU or SCL or eSCL	CANopen
Pulse signal type	Pulse/Direction CW/CCW Pulse A/B Quadrature	Pulse/Direction CW/CCW Pulse A/B Quadrature	-
Maximum Input Pulse Frequency	2MHz, Min. Pulse Width=250ns	2MHz, Min. Pulse Width=250ns	-
Digital Inputs	4	8	8
Digital Outputs	3	4	4
Analog Inputs	-	1	1
Encoder Output	20,000 counts/rev A/B/Z differential	20,000 counts/rev A/B/Z differential	20,000 counts/rev A/B/Z differential
Digital Input	Optically isolated, 5-24VDC		
Digital Output	Optically isolated, 30VDC/100mA		
Analog Input	AIN referenced to GND, Range 0-5VDC, Resolution: 12bits		
Supply Voltage	Main power: 24-70VDC AUX power: 12-48VDC		
Protection	Over-voltage, under-voltage, over-temp, motor/wiring shorts (phase-to-phase, phase-to-ground)		

Enter motor length 1, 3, 5, 6 in the box (■) within the model name

Enter A (RS-232) or R (RS-485) or D (Dual port Ethernet) in the box (□) within the model name

◇ General Specifications

		TSM Integrated Step-Servo
Insulation Class		Class B (130°C)
Insulation Resistance		100M Ω/DC500V
Dielectric Strength		500VAC 1 minute
Operating Environment	Ambient Temperature	0~+40°C
	Ambient Humidity	90% or less (non-condensing)
	Atmosphere	No corrosive gases, dust, water or oil
Degree of Protection		IP20

◇ RS-485 or Modbus/RTU Specifications

Interface	RS-485 or Modbus/RTU
Baud Rate (bps)	9600/19200/38400/57600/115200
Maximum Distance	Due to transmission baud rate
Maximum Connections	32 axes per channel
Communication Cable	Twisted Shielded Cable
Address Setting	Via Stepper Suite

◇ CANopen Specifications

Interface	CANopen CiA301 CiA402
Baud Rate (bps)	1M/800K/500K/250K/125K/50K/20K/12.5K
Maximum Distance	Due to transmission baud rate
Maximum Connections	112 axes per channel
Communication Cable	Twisted Shielded Cable
Address Setting	Via on board rotary switch and Stepper Suite software

◇ Ethernet Specifications

Interface	Ethernet(eSCL)
Baud Rate (bps)	100Mbps
Maximum Distance	100 meters between 2 devices
Communication Cable	Shielded twisted pair cable (CAT5e or CAT6)
Address Setting	Via Stepper Suite

◇ Permissible Shaft Loading and Permissible Thrust Load (Unit: N)

Frame Size	Model	Permissible Shaft Loading					Permissible Thrust Load
		Distance (L) from Shaft end (mm)					
		0	5	10	15	20	
28mm	TSM11□-1RM	20	25	34	52	-	Less than the motor mass
	TSM11□-2RM						
	TSM11□-3RM						
42mm	TSM17□-1□G	35	44	58	85	-	
	TSM17□-2□G						
	TSM17□-3□G						
	TSM17□-4□G						
56mm	TSM23□-2□G	63	75	95	130	190	
	TSM23□-3□G						
	TSM23□-4□G						
60mm	TSM24□-3□G	90	100	130	180	270	
86mm	TSM34□-1□G	260	290	340	390	480	
	TSM34□-3□G						
	TSM34□-5□G						
	TSM34□-6□G						

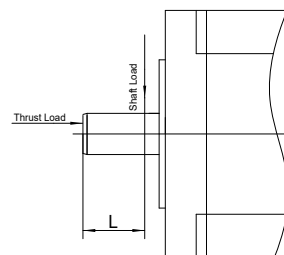

Optional Accessories

P/N	Category	Technical Specifications
RC880	Regeneration Clamp	80VDC Max. 50W
MS-USB-RS232-01	USB Converter	USB-RS232
MS-USB-RS485-01	USB Converter	USB-RS485
MS-USB-CAN-01	USB Converter	USB-CAN
1101-□□□	Cable	I/O cable, unshielded
1116-□□□	Cable	I/O cable, shielded
2101-150	Cable	RS-232 communication cable (P/Q type)
2113-150	Cable	RS-232 communication cable (C type)
2111-□□□	Cable	RS-485 Daisy Chain
2112-□□□	Cable	CANopen Daisy Chain
2012-030	Cable	CAT5e UTP 0.3m
2012-300	Cable	CAT5e UTP 3m
2013-030	Cable	CAT5e UTP 0.3m
2013-300	Cable	CAT5e UTP 3m

* □□□ stands for length, unit:cm, ex.100 stands for 100cm

◇ General Purpose I/O Cable(unshielded)(TSM17/23/24/34)

P/N	Length (L)
1101-100	1m
1101-200	2m
1101-500	5m

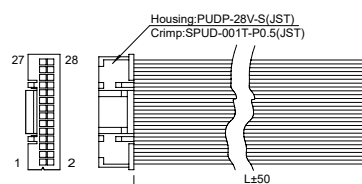

Pin No.	Assignment	Description	Color	Pin No.	Assignment	Description	Color
1	X1+	High Speed Digital Input	BLU	15	X8+	X8 Digital Input	GRN
2	X1-		BLU/WHT	16	X8-		GRN/WHT
3	X2+	High Speed Digital Input	YEL	17	Y1	Y1 Digital Output	BLU
4	X2-		YEL/WHT	18	Y2	Y2 Digital Output	YEL
5	X3	X3 Digital Input	GRN	19	Y3	Y3 Digital Output	BRN
6	X4	X4 Digital Input	ORG	20	YCOM	Y Output COM	BLK
7	X5	X5 Digital Input	GRY	21	Y4+	Y4 Digital Output	RED
8	X6	X6 Digital Input	PUR	22	Y4-		RED/WHT
9	XCOM	X Digital Input COM	WHT	23	Z+	Encoder Output Z (if applicable)	BLK
10	+5V	+5V Analog Voltage	RED	24	Z-	Encoder Output Z (if applicable)	BLK/WHT
11	AIN	Analog Input	BLU	25	B+	Encoder Output B (if applicable)	GRN
12	GND	Analog Input	BLK	26	B-	Encoder Output B (if applicable)	GRN/WHT
13	X7+	X7 Digital Input	ORG	27	A+	Encoder Output A (if applicable)	ORG
14	X7-		ORG/WHT	28	A-		ORG/WHT

◇ General Purpose I/O Cable (shielded) (TSM17/23/24/34)

P/N	Length (L)
1116-100	1m
1116-200	2m
1116-300	3m
1116-500	5m

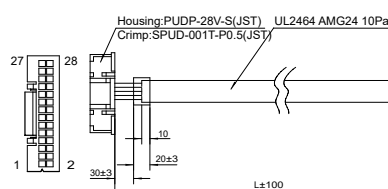

Pin No.	Assignment	Description	Color	Pin No.	Assignment	Description	Color
1	X1+	High Speed Digital Input	BLU/WHT	15	X8+	X8 Digital Input	GRY/WHT
2	X1-		BLU/BLK	16	X8-		GRY/BLK
3	X2+	High Speed Digital Input	GRN/WHT	17	Y1	Y1 Digital Output	BRN
4	X2-		GRN/BLK	18	Y2	Y2 Digital Output	GRY
5	X3	X3 Digital Input	BLU	19	Y3	Y3 Digital Output	PNK
6	X4	X4 Digital Input	PUR	20	YCOM	Y Output COM	YEL/GRN
7	X5	X5 Digital Input	YEL	21	Y4+	Y4 Digital Output	PUR/WHT
8	X6	X6 Digital Input	GRN	22	Y4-		PUR/BLK
9	XCOM	X Digital Input COM	ORG	23	Z+	Encoder Output Z (if applicable)	YEL/WHT
10	+5V	+5V Analog Voltage	RED	24	Z-	Encoder Output Z (if applicable)	YEL/BLK
11	AIN	Analog Input	WHT	25	B+	Encoder Output B (if applicable)	ORG/WHT
12	GND	GND	BLK	26	B-	Encoder Output B (if applicable)	ORG/BLK
13	X7+	X7 Digital Input	BRN/WHT	27	A+	Encoder Output A (if applicable)	RED/WHT
14	X7-		BRN/BLK	28	A-		RED/BLK

◇ Power + Comm + I/O Cable (Flying leads TSM11 only)

Model	Length (L)
1109-030	0.3m

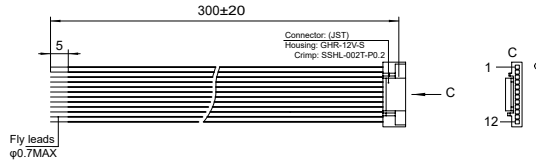

Pin No.	Assignment	Description	Color	Pin No.	Assignment	Description	Color
1	Y2	Y2 Digital Output	PUR	7	RXD-	RS-422/485 Data Receive-	GRN/WHT
2	Y1	Y1 Digital Output	ORG	8	RXD+	RS-422/485 Data Receive+	GRN
3	X4	X4 Digital Input	WHT	9	TXD-	RS-422/485 Data Transmit-	BLU/WHT
4	X3	X3 Digital Input	BRN	10	TXD+	RS-422/485 Data Transmit+	BLU
5	X2	High Speed Digital Input	YEL	11	V+	Power Supply +	RED
6	X1	High Speed Digital Input	GRY	12	V-	Power GND	BLK

◇ RS-485 Daisy Chain Communication Cable (TSM17/23/24/34)

Model	Length (L)
2111-025	0.25m
2111-050	0.5m
2111-100	1m
2111-300	3m

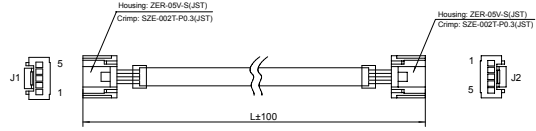

◇ RS-232 Communication Cable(P/S/Q Type)(TSM23/24/34)

Model	Length (L)
2101-150	1.5m

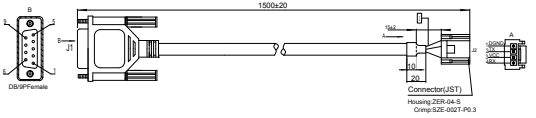

◇ CANopen Daisy Chain Communication Cable(TSM17/23/24/34)

Model	Length (L)
2112-025	0.25m
2112-050	0.5m
2112-100	1m
2112-300	3m

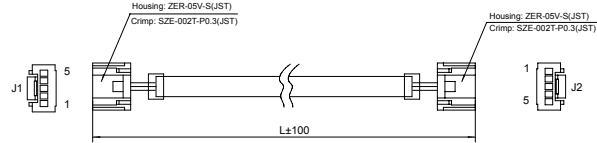

◇ RS-232 Communication Cable(C Type)(TSM17/23/24/34)

Model	Length (L)
2113-150	1.5m

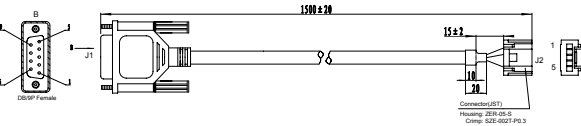

◇ Ethernet Daisy Chain Communication Cable (Q/IP Type) (TSM34 only)

Common Type	Shielded Type	Length (L)
2012-030	2013-030	0.3m
2012-300	2013-300	3m

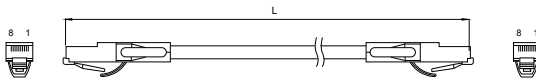

TXM Series Integrated Step-Servo Motor



■ TXM Series Features

- Up to 3 digital inputs, 1 digital outputs and 1 analog inputs for TXM24S/Q/IP type
- Up to 5 digital inputs, 3 digital outputs and 1 analog inputs for TXM34Q/C/IP type
- A/B/Z differential encoder signal output supported for TXM34P type
- On board daisy chain connection for field bus control (RS-485, Modbus/RTU, CANopen)
- On board daisy chain connection for Ethernet control (TXM34 only)
- Multiple homing methods
- Software limit
- AUX Power supply, when the main power cut off, the AUX power can make the control circuits working normally (TXM34 only)
- IP65 protection class

■ Numbering System

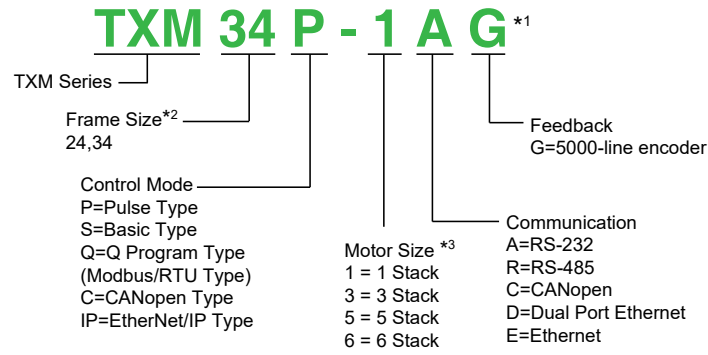

Note:

*1 See ordering information table below for available model.

*2 Refers to the size of the motor mounting surface: 24 (60mm), 34 (86mm).

*3 Please refer to the mechanical dimension drawing of the corresponding model for the specific length.

■ Ordering Information

Model	Torque	Control	I/O(*)	RS-232	RS-485/422	Modbus/RTU	CANopen	Ethernet	EtherNet/IP	
TXM24S-3AG	2.5N.m	S	3DI,1DO,1AI	√						
TXM24S-3RG					√					
TXM24S-3EG									√	
TXM24Q-3AG		Q			√		√			
TXM24Q-3RG						√	√			
TXM24Q-3EG									√	
TXM24IP-3EG				IP					√	√
TXM24C-3CG	C	5DI,3DO	√			√				
TXM34P-1AG	2.7N.m	P	4DI,3DO,EO	√						
TXM34Q-1AG		Q	5DI,3DO,1AI	√		√				
TXM34Q-1RG						√	√			
TXM34Q-1DG									√	
TXM34C-1CG		C			√			√		
TXM34IP-1DG		IP							√	√
TXM34P-3AG	5.2N.m	P		4DI,3DO,EO	√					
TXM34Q-3AG		Q	5DI,3DO,1AI	√		√				
TXM34Q-3RG						√	√			
TXM34Q-3DG									√	
TXM34C-3CG		C			√			√		
TXM34IP-3DG		IP							√	√
TXM34P-5AG	6.7N.m	P		4DI,3DO,EO	√					
TXM34Q-5AG		Q	5DI,3DO,1AI	√		√				
TXM34Q-5RG						√	√			
TXM34Q-5DG									√	
TXM34C-5CG		C			√			√		
TXM34IP-5DG		IP							√	√
TXM34P-6AG	8.2N.m	P		4DI,3DO,EO	√					
TXM34Q-6AG		Q	5DI,3DO,1AI	√		√				
TXM34Q-6RG						√	√			
TXM34Q-6DG									√	
TXM34C-6CG		C			√			√		
TXM34IP-6DG		IP							√	√

* DI: Digital Input; DO: Digital Output; EO: Encoder Output; AI: Analog Input

System configuration

◇ -P Pulse Input type(TXM34 only)

Controlled via pulse generator.

Main Features

- Accepts three types of pulse signal input as Pulse&Direction, CW/CCW and A/B Quadrature
- Encoder signal output, A/B/Z differential

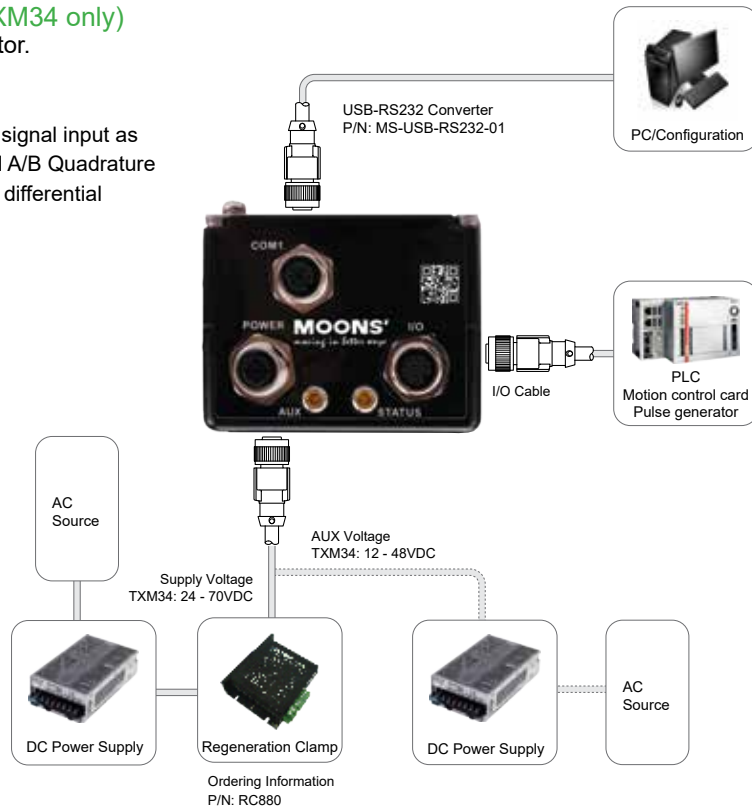

◇ -S Basic Type (TXM24 only)

Controlled via pulse signals, analog signal or MOONS' SCL streaming serial commands.

Main Features

- Pulse control
- Analog control
- Host real time control using SCL via RS-232/RS-485
- Up to 32 axes per channel for RS-485
- Host real time control using SCL via Ethernet UDP/TCP

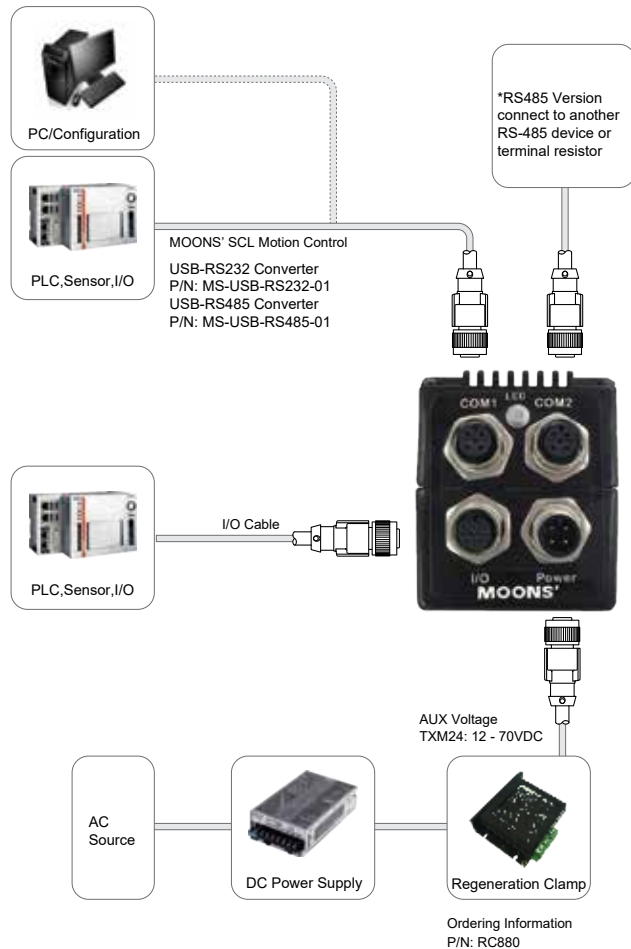

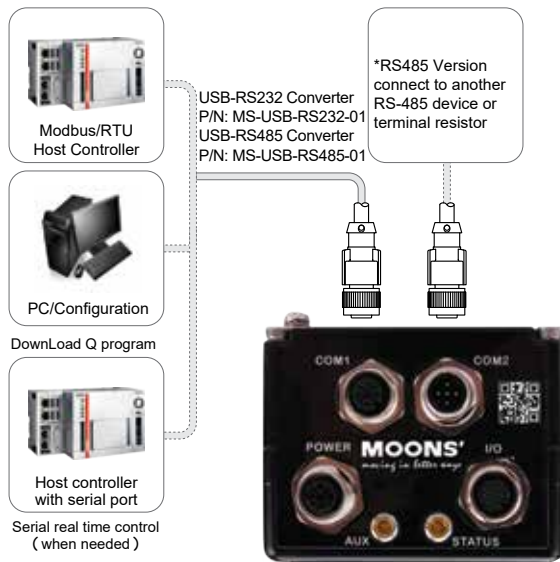

◇ -Q Built-in Programmable Motion Controller (Includes Modbus/RTU Type) (Includes Ethernet TCP/UDP type)

Run stand-alone with sophisticated and functional programs. Commands for controlling motion, inputs & outputs, drive configuration and status, as well as math operations, register manipulation, and multi-tasking.

Main Features

- Stand-alone operation plus Serial host control
- Math operations
- Register manipulation
- Multi-tasking
- Modbus/RTU network, up to 32 axes per channel
- Host real time control using SCL via Ethernet UDP/TCP

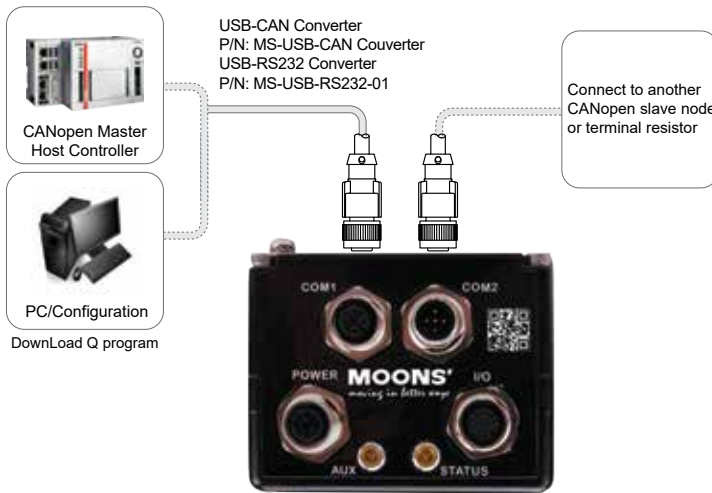
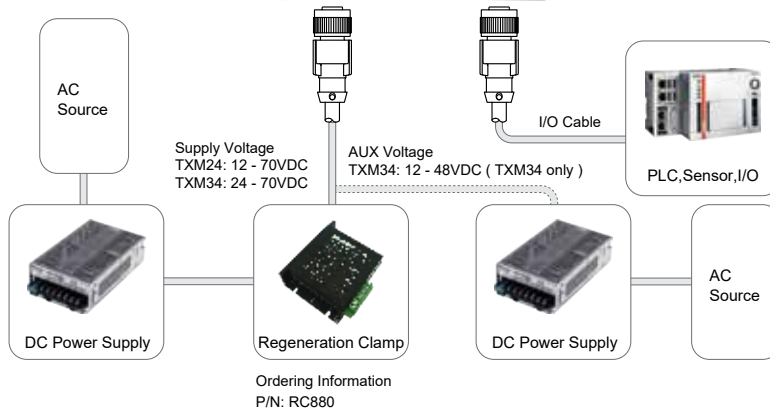

◇ -C CANopen Type

Operates on a CANopen communication network and conforms to CiA301 and CiA402. Supports running stored Q programs via MOONS'-specific CANopen objects.

Main Features

- CANopen network
- Up to 112 axes per channel
- Objects for Q programming

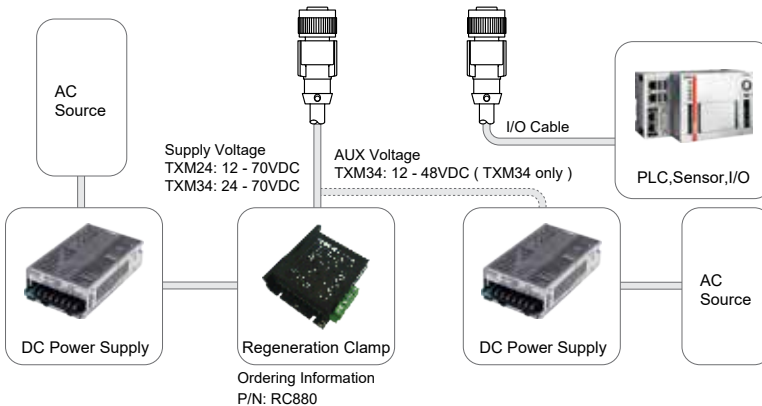

◇ -IP EtherNet/IP Type

Operates on a EtherNet/IP communication network. Supports running stored Q programs via MOONS'-specific EtherNet/IP objects.

Main Features

- EtherNet/IP network
- Objects for Q programming
- SCL

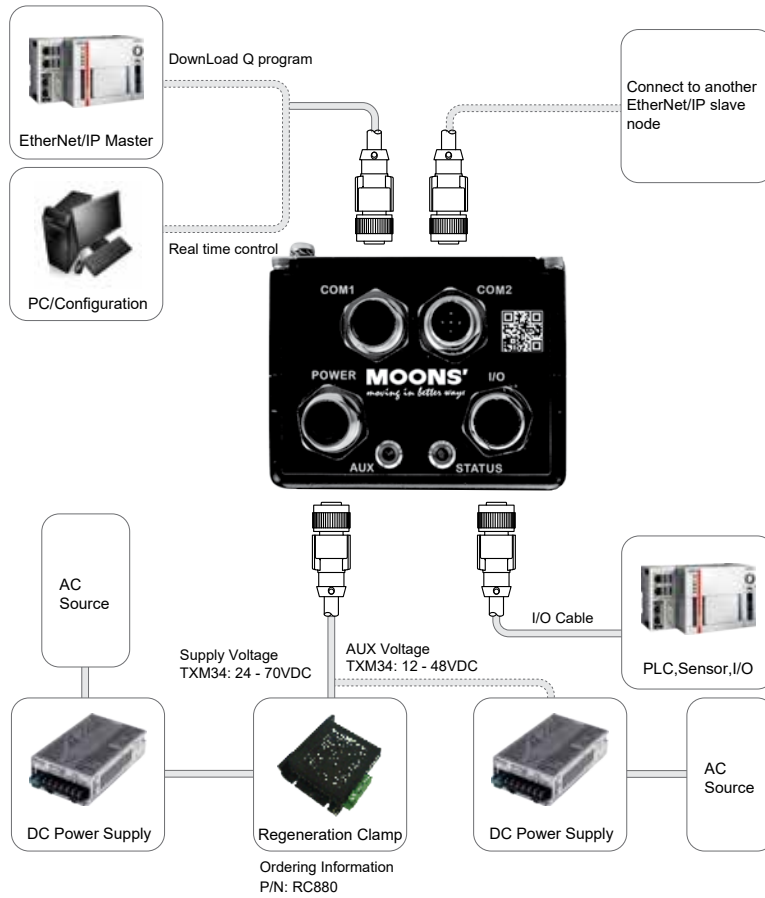

Specifications

◇ Frame size 60mm

Model	Basic type	TXM24S-3□G
	Q program type (Includes Modbus/RTU type)	TXM24Q-3□G
	CANopen type	TXM24C-3CG
	EtherNet/IP type	TXM24IP-3EG
Torque	N·m	2.5
Rotor Inertia	g·cm ²	900
Supply Voltage	VDC	12-70
Encoder Resolution	counts/rev	20000
Maximum Speed	RPM	3600
Mass	g	2090

Enter A(RS232) or R(RS485) or E(Ethernet) in the box(□) within the model name

◇ Torque Curves

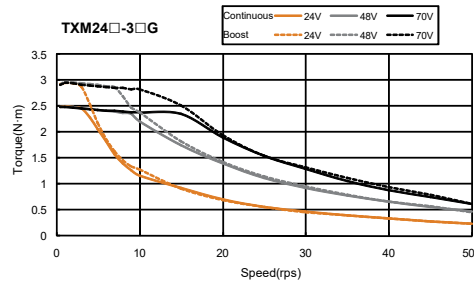

◇ Electrical Specifications

	Basic Type TXM24S-3□G	Q program type TXM24Q-3□G	CANopen type TXM24C-3CG	EtherNet/IP Type TXM24IP-3EG
Control Command	Pulse input Analog signal SCL SCL or eSCL	Pulse input Analog signal SCL or eSCL Q program Modbus/RTU	Q program CANopen	Q program EtherNet/IP
Communication	RS-232 or RS-485 or Ethernet	RS-232 or RS-485 or Ethernet	RS-232&CANopen	Ethernet
Protocol	SCL	Modbus/RTU or SCL	CANopen	EtherNet/IP
Pulse signal type	Pulse/Direction CW/CCW Pulse A/B Quadrature	Pulse/Direction CW/CCW Pulse A/B Quadrature	-	-
Maximum Input Pulse Frequency	2MHz, Min. Pulse Width=250ns	2MHz, Min. Pulse Width=250ns	-	-
Digital Inputs	3	3	5	3
Digital Outputs	1	1	3	1
Analog Inputs	1	1	-	1
Digital Input	Optically isolated, 5-24VDC			
Digital Output	Optically isolated, 30VDC/100mA			
Analog Input Specification	AIN referenced to GND, Range 0-5VDC, Resolution: 12bits	-	-	AIN referenced to GND, Range 0-5VDC, Resolution: 12bits
Supply Voltage	12-70VDC			
Protection	Over-voltage, under-voltage, over-temp, motor/wiring shorts (phase-to-phase, phase-to-ground)			

Enter A(RS232) or R(RS485) or E(Ethernet) in the box(□) within the model name

◇ Frame size 86mm

Model	Pulse input type	TXM34P-1AG	TXM34P-3AG	TXM34P-5AG	TXM34P-6AG
	Q program type (Includes Modbus/RTU type)	TXM34Q-1□G	TXM34Q-3□G	TXM34Q-5□G	TXM34Q-6□G
	CANopen type	TXM34C-1CG	TXM34C-3CG	TXM34C-5CG	TXM34C-6CG
	EtherNet/IP type	TXM34IP-1DG	TXM34IP-3DG	TXM34IP-5DG	TXM34IP-6DG
Torque	N·m	2.7	5.2	6.7	8.2
Rotor Inertia	g·cm ²	915	1480	2200	3660
Supply Voltage	VDC	24-70			
Encoder Resolution	counts/rev	20000	20000	20000	20000
Maximum Speed	RPM	3600	3600	3600	3600
Mass	g	4600	6800	9000	11400

Enter A(RS232) or R(RS485) or D(Dual port Ethernet) in the box(□) within the model name

◇ Torque Curves

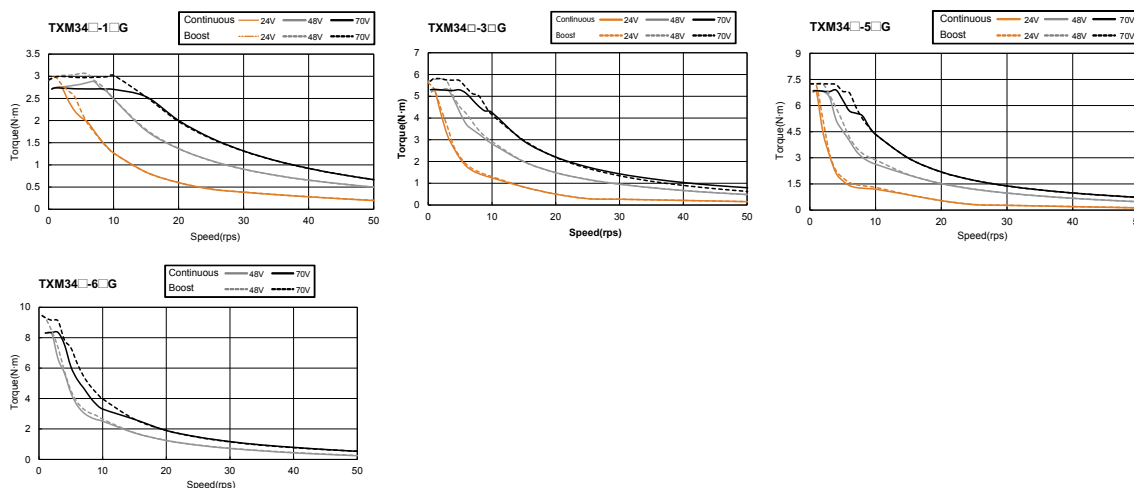

◇ Electrical Specifications

	Pulse input type TXM34P-■AG	Q program type TXM34Q-■□G	CANopen type TXM34C-■CG	EtherNet/IP type TXM34IP-■CG
Control Command	Pulse input	Pulse input Analog signal SCL or eSCL Q program Modbus/RTU	Q program CANopen	Q program EtherNet/IP
Communication	RS-232	RS-232 or RS-485 or Ethernet	RS-232&CANopen	Ethernet
Protocol	-	Modbus/RTU or SCL or eSCL	CANopen	EtherNet/IP
Pulse signal type	Pulse/Direction CW/CCW Pulse A/B Quadrature	Pulse/Direction CW/CCW Pulse A/B Quadrature	-	-
Maximum Input Pulse Frequency	2MHz, Min. Pulse Width=250ns	2MHz, Min. Pulse Width=250ns	-	-
Digital Inputs	4	5	5	5
Digital Outputs	3	3	3	3
Analog Inputs	-	1	1	1
Encoder Output	20,000 counts/rev A/B/Z differential	-	-	-
Digital Input	Optically isolated, 5-24VDC			
Digital Output	Optically isolated, 30VDC/100mA			
Analog Input Specification	-	AIN referenced to GND, Range 0–5VDC, Resolution: 12bits		
Supply Voltage	Main power: 24-70VDC AUX power: 12-48VDC			
Protection	Over-voltage, under-voltage, over-temp, motor/wiring shorts (phase-to-phase, phase-to-ground)			

Enter motor length 1,3,5,6 in the box(■) within the model name
Enter A(RS232) or R(RS485) or D(Dual port Ethernet) in the box(□) within the model name

◇ General Specifications

		TXM Integrated Step-Servo
Insulation Class		Class B (130°C)
Insulation Resistance		100M Ω/DC500V
Dielectric Strength		500VAC 1 minute
Operating Environment	Ambient Temperature	0~+40°C
	Ambient Humidity	90% or less (non-condensing)
	Atmosphere	No corrosive gases, dust, water or oil
Degree of Protection		IP65

◇ RS-485 or Modbus/RTU Specifications

Interface	RS-485 or Modbus/RTU
Baud Rate (bps)	9600/19200/38400/57600/115200
Maximum Distance	Due to transmission baud rate
Maximum Connections	32 axes per channel
Communication Cable	Twisted Shielded Cable
Address Setting	Via Stepper Suite

◇ CANopen Specifications

Interface	CANopen CiA301 CiA402
Baud Rate (bps)	1M/800K/500K/250K/125K/50K/20K/12.5K
Maximum Distance	Due to transmission baud rate
Maximum Connections	112
Communication Cable	Twisted Shielded Cable
Address Setting	Via Stepper Suite

◇ Ethernet Specifications

Interface	Ethernet(eSCL)
Baud Rate (bps)	100Mbps
Maximum Distance	100 meters between 2 devices
Communication Cable	Twisted Shielded Cable
Address Setting	Via Stepper Suite

◇ Permissible Overhung Load and Permissible Thrust Load(Unit:N)

Frame size	Model	Permissible Overhung Load					Permissible Thrust Load
		Distance(L) from Shaft End(mm)					
		0	5	10	15	20	
60mm	TXM24□-3□G	90	100	130	180	270	Less than the motor mass
86mm	TXM34□-1□G	260	290	340	390	480	
	TXM34□-3□G						
	TXM34□-5□G						
	TXM34□-6□G						

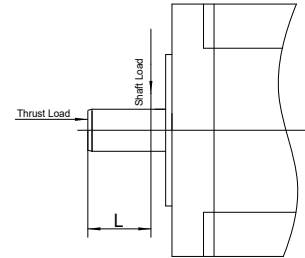

■ Dimensions(Unit:mm)

◇ TXM24

Model	“L”	“M”	front shaft diameter
TXM24□-3□G	131.3	60.5	10

* 8mm diameter shaft available per request

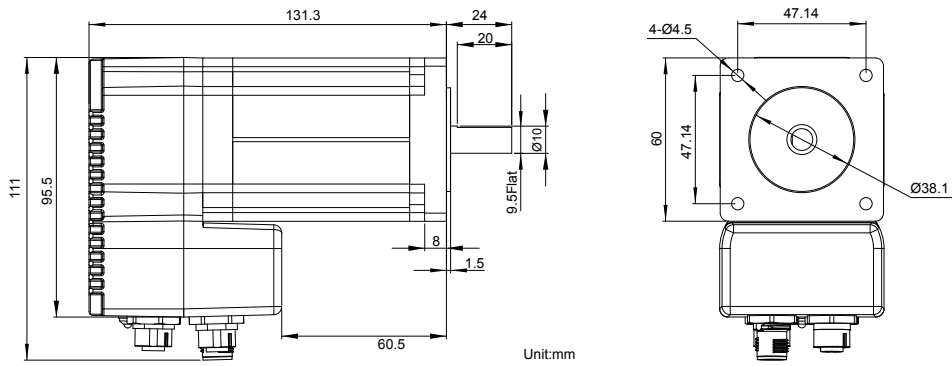

◇ TXM34

Model	“L”	front shaft diameter
TXM34□-1□G	112.5	14
TXM34□-3□G	143	
TXM34□-5□G	172.5	
TXM34□-6□G	203	

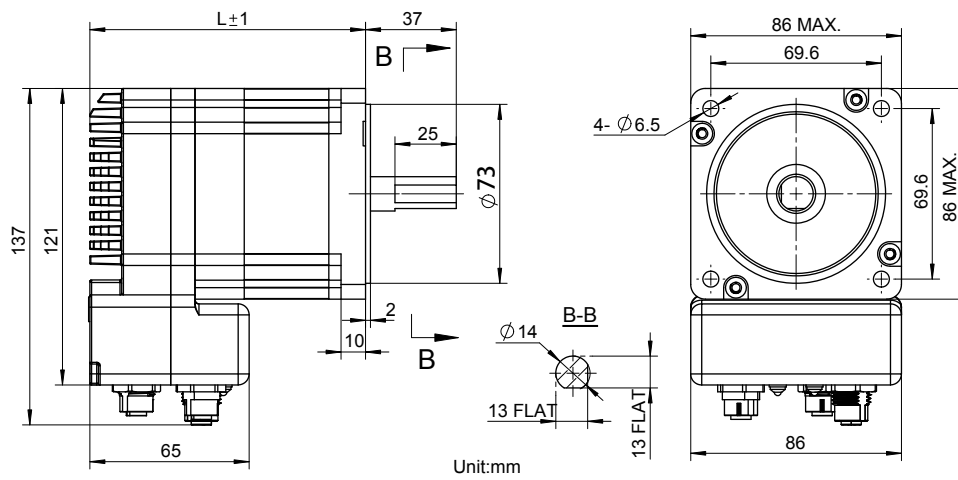

■ Accessories

◇ Optional Accessories

Model	Category	Description
RC880	Regeneration Clamp	80VDC Max. 50W
MS-USB-RS232-01	USB Converter	USB-RS232
MS-USB-RS485-01	USB Converter	USB-RS485
MS-USB-CAN-01	USB Converter	USB-CAN

◇ TXM24 Series Cable

● I/O Cable

Model	Vendor	Description
1430048	Phoenix Contact	12pin, 1.5m, shielded, A-coded

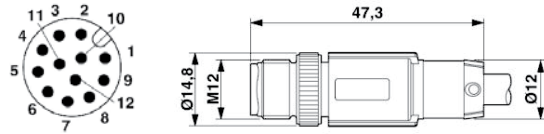

-S/Q/IP Type				-C Type			
Pin No.	Assignment	Description	Color	Pin No.	Assignment	Description	Color
1	Step+	High Speed Digital Input	BRN	1	X1+	High Speed Digital Input	BRN
3	Step-		WHT	3	X1-		WHT
5	Dir+	High Speed Digital Input	PNK	5	X2+	High Speed Digital Input	PNK
8	Dir-		GRY	8	X2-		GRY
6	En+	X3 Digital Input	YEL	4	X3	X3 Digital Input	GRN
4	En-		GRN	6	X4	X4 Digital Input	YEL
11	OUT+	Digital Output	GRY/PNK	7	X5	X5 Digital Input	BLK
12	OUT-		RED/BLU	10	XCOM	X Output COM	PUR
9	+5V	+5V Analog Voltage	RED	11	Y1	Y1 Digital Output	GRY/PNK
10	AIN	Analog Input	PUR	12	Y2	Y2 Digital Output	RED/BLU
7	GND	Analog Input Ground	BLK	9	Y3	Y3 Digital Output	RED
2	N/C	-	BLU	2	YCOM	Y Output COM	BLU

● Power Cable

Model	Vendor	Description
1404407	Phoenix Contact	3m, unshielded, A-coded

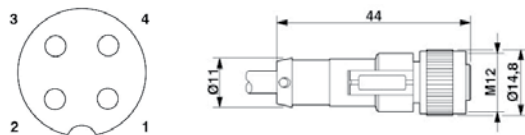

● RS-232/RS-485/CANopen Communication Cable

Model	Vendor	Description
1518960	Phoenix Contact	1.5m, unshielded, A-coded

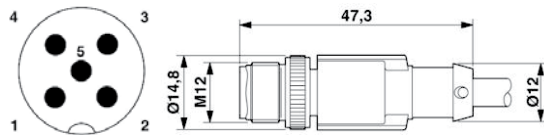

● Ethernet Communication Cable

Model	Vendor	Description
1407356	Phoenix Contact	1m, CAT5e shielded, D-coded

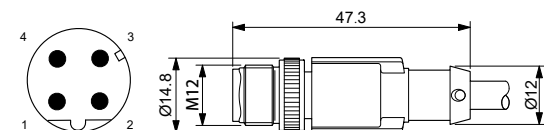

◇ TXM34 Series Cable

● I/O Cable

Model	Vendor	Description
1430200	Phoenix Contact	17 PIN, 1.5m, shielded, A-coded

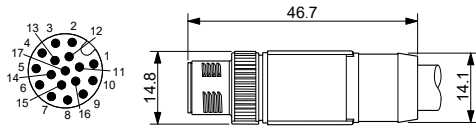

-P Type				-Q/C/IP Type			
Pin No.	Assignment	Description	Color	Pin No.	Assignment	Description	Color
1	X1+	High Speed Digital Input	BRN	1	X1+	High Speed Digital Input	BRN
3	X1-		WHT	3	X1-		WHT
6	X2+	High Speed Digital Input	YEL	6	X2+	High Speed Digital Input	YEL
4	X2-		GRN	4	X2-		GRN
5	X3	X3 Digital Input	PNK	5	X3+	X3 Digital Input	PNK
8	X4	X4 Digital Input	GRY	8	X3-		GRY
7	XCOM	X Digital Input COM	BLK	7	X4+	X4 Digital Input	BLK
10	YCOM	Y Digital Input COM	PUR	10	X4-		PUR
9	ENC A+	Encoder Output A+	RED	9	X5+	X5 Digital Input	RED
2	ENC A-	Encoder Output A-	BLU	2	X5-		BLU
11	ENC B+	Encoder Output B+	GRY/PNK	11	Y1	Y1 Digital Output	GRY/PNK
12	ENC B-	Encoder Output B-	RED/BLU	12	Y2	Y2 Digital Output	RED/BLU
13	ENC Z+	Encoder Output Z+	WHT/GRN	13	Y3	Y3 Digital Output	WHT/GRN
14	ENC Z-	Encoder Output Z-	BRN/GRN	14	YCOM	Y Digital Input COM	BRN/GRN
15	Y1	Y1 Digital Output	WHT/YEL	15	GND	Analog Input Ground	WHT/YEL
16	Y2	Y2 Digital Output	YEL/BRN	16	+5V	+5V Analog Voltage	YEL/BRN
17	Y3	Y3 Digital Output	WHT/GRY	17	AIN	Analog Input	WHT/GRY

● Power Cable

Model	Vendor	Description
1408835	Phoenix Contact	1m, shielded, S-code

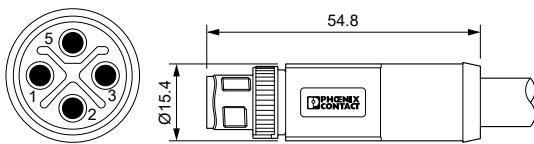

● RS232/RS485/CANopen Communication Cable

Model	Vendor	Description	COM Port
1682744	Phoenix Contact	3m, plug, shielded, A-code	COM1
1682948		3m, Socket, shielded, A-code	COM2

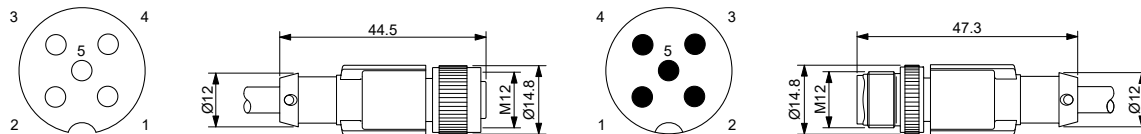

● Ethernet Communication Cable

Model	Vendor	Description
1407356	Phoenix Contact	1m, CAT5e shielded, D-code

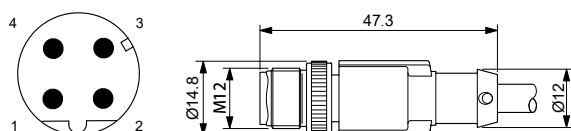

■ User Software

Features



Stepper Suite

Software Features

- Friendly User Interface
- Easy setup within just three steps
- Drive setup and configuration
- Servo Tuning and Sampling
- Built-in Q programmer
- Motion testing and monitoring
- Write and save SCL command scripts
- Online help integrated
- Support all products in RSM/SSM/TSM/TXM/RS/SS/SSDCSeries and STF Stepper Driver

Efficient
Integrated
TSM



RS485 Bus Utility

Software Features

- Stream SCL commands from the command line
- Simple interface with powerful capability
- Easy setup with RS-485 for 32 axis network motion control
- Monitoring Status of I/O, drive, alarm and the other nine most useful motion parameters
- Write and save SCL command scripts
- Online help integrated
- Supports all RS-485 drives

IP65
Integrated
TXM

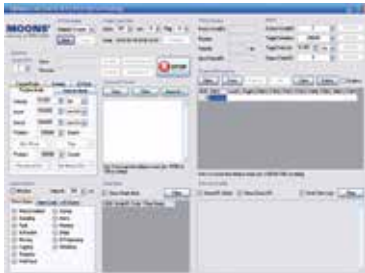

CANopen Test Tool

Software Features

- Intuitive interface
- Drive status and alarm monitoring
- Self-test function to test drive/motor operation
- Built-in SCL Terminal
- Online help integrated
- Supports all ST and STAC stepper drives
- Supports all STM and SWM integrated steppers

All software applications run on Windows 7/8/10, 32-bit or 64-bit.

FREE DOWNLOAD

Our software and user manual can be downloaded from our website:
www.moonsindustries.com

Appendix

■ Accessories

◇ Regeneration Clamp

P/N: RC880

When using regulated power supply you may encounter a problem with regeneration. The kinetic energy caused by regeneration is transferred back to the power supply. This can trip the overvoltage protection of a switching power supply, causing it to shut down.

MOONS' offer the RC880 “regeneration clamp” to solve this problem. If in doubt, use an RC880 for your first installation. If the “regen” LED on the RC880 never flashes, you don't need the clamp.

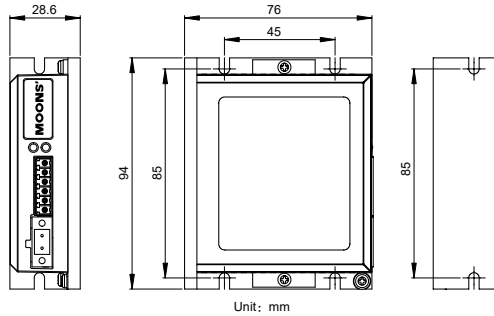

◇ USB Converter

Model: MS-USB-RS232-01

Description: USB-RS-232 converter



Model: MS-USB-RS485-01

Description: USB-RS-485 converter



Model: MS-USB-CAN-01

Description: USB-CAN converter



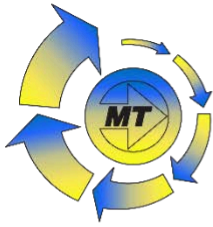

Distributors for Australia & New Zealand

MOTION TECHNOLOGIES PTY LIMITED



24/22-30 Northumberland Road
Caringbah NSW 2229 Australia
Phone: (02) 9524 4782

sales@motiontech.com.au
www.motiontech.com.au

© 08/10/2024



<https://www.moonsindustries.com/>
E-mail: ama-info@moons.com.cn
MOONS'
moving in better ways

• All the specifications, technical parameters of the products provided in this catalog are for reference only, subject to change without notice. For the latest details, please contact our sales department.